



## Top Signal Home Cell Phone Signal Booster Manual



[www.PowerfulSignal.com](http://www.PowerfulSignal.com)

Operational Diagram  
(How It Works)  
Package Contents  
Page 2

Basic Signal Level Knowledge  
Page 3

Preparation  
Pages 4–7

Installation Step By Step  
Pages 8–16

Troubleshooting  
Pages 17–18

Technical Specification  
Warranty Information  
Page 19

Safety Guidelines  
Page 20

Customer service:  
(435) 634-6800

# Working Diagram (How It Works)



1. The outdoor antenna receives the signal from the tower.
2. Sends outside signal to the booster through a coax cable.
3. The booster amplifies the signal then rebroadcasts the signal indoors to all mobile devices within range.
4. The system also works in reverse, amplifying outgoing signal back to the tower.

**⚠** The **size** of the coverage area and the **strength** of the boosted signal are directly related to two key factors:

1. The signal strength received by the outdoor antenna. Setting up external antenna where the signal is strongest will provide the best results.
2. Distance or **separation** between the outdoor and the indoor antennas.

## Package Contents

The kit includes the following items:

1. Outdoor antenna, indoor antenna(s)
2. Booster
3. Power supply
4. Splitter (for 2-antenna systems)
5. Coax cable



Outdoor Antenna



Indoor Antenna(s)



Booster



Power supply



Splitter



Coax cable

# Signal transmission loss and power level

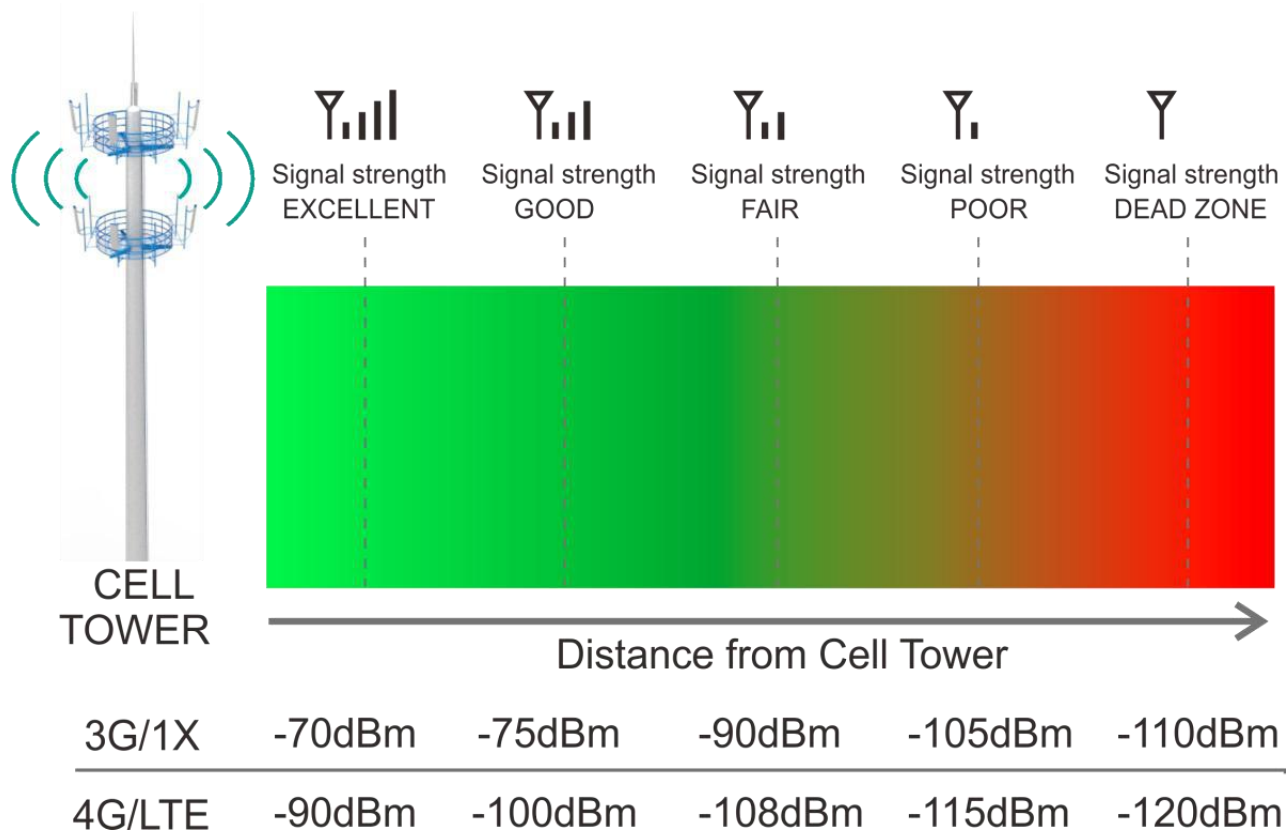

# Coverage area ability

**Note:** FCC regulations limit the amplification of all cell phone boosters in order to prevent damage to the telecommunications infrastructure. Therefore, the maximum coverage area of a booster depends on the original power level of the signal captured by the outdoor unit.

**! Notice:** Not recommended when outdoor signal strength is less than -110dbm (3G/1x) or -120dBm (4G/LTE). The resulting coverage area of the boosted signal will be prohibitively small.

Power level at the outdoor antenna location	Coverage Area (sq. ft.)
Strong (5 bars on the cellphone)	8,000
Medium (3~4 bars on the cellphone)	3,500
Weak (1~2 bars on the cellphone)	1,000

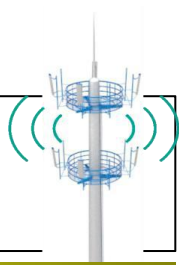

## Find your cell tower nearby!

There are a variety of resources available online. Here is a third party website we recommend; use it to locate your nearest cell tower: [www.cellmapper.net](http://www.cellmapper.net)

**Note:** This is very important step. If you use the wrong direction, you won't have good results.

## Step 1: Visit website [www.cellmapper.net](http://www.cellmapper.net)

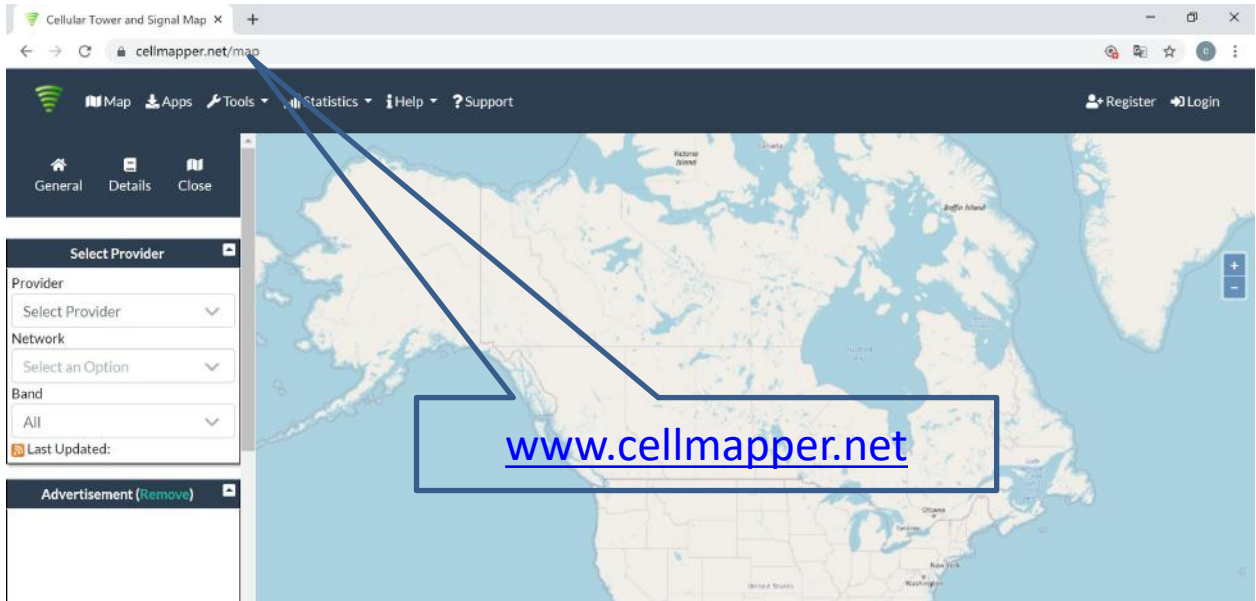

## Step 2: Find your location on the map and zoom in on your area

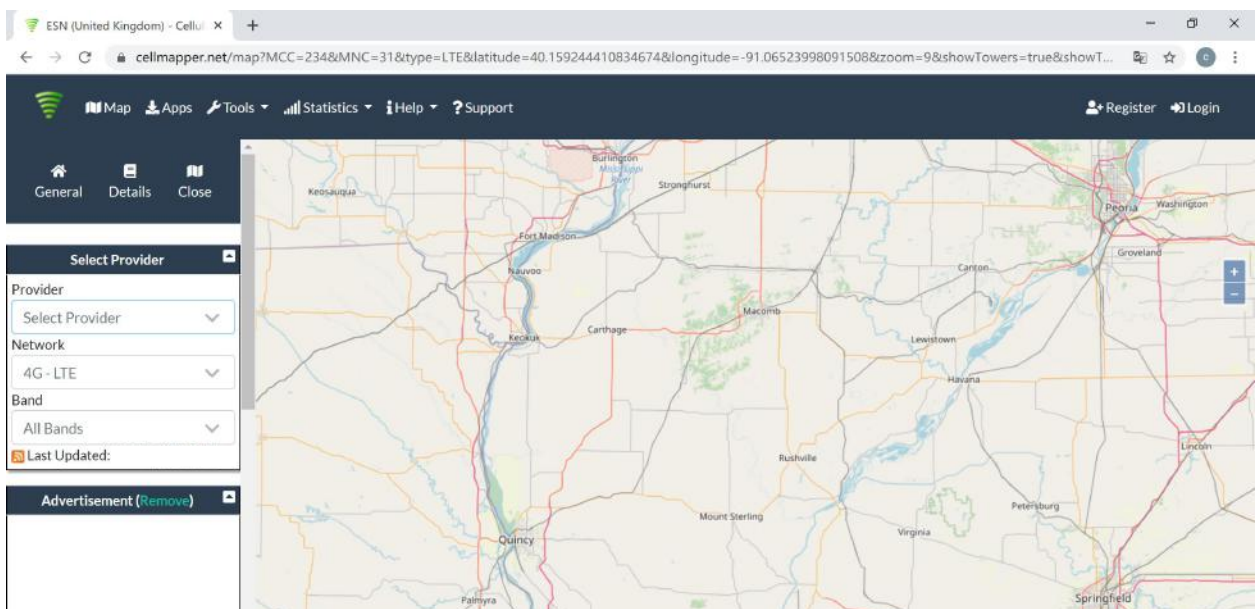

# Step 3: Select Provider. You will find the cell towers around your house.

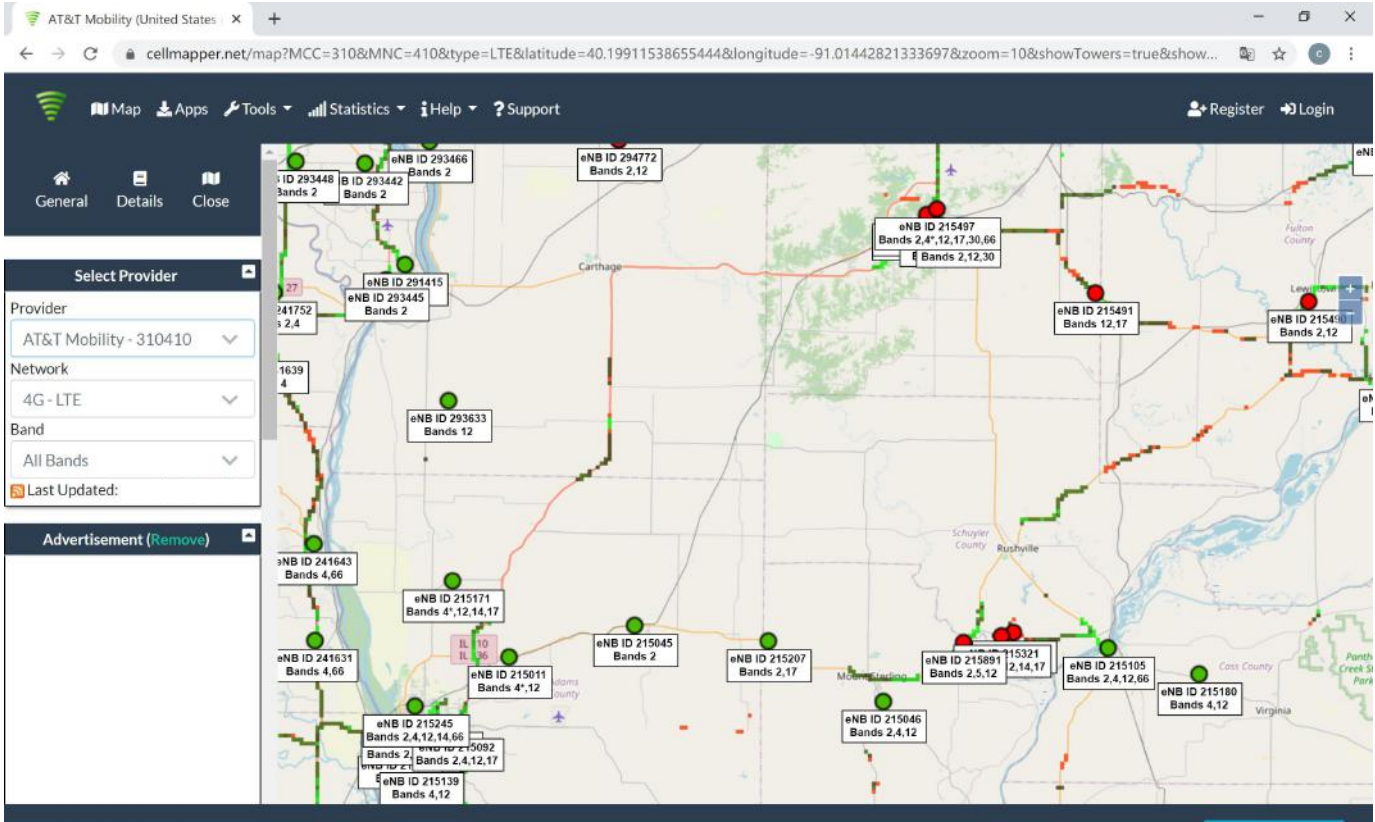
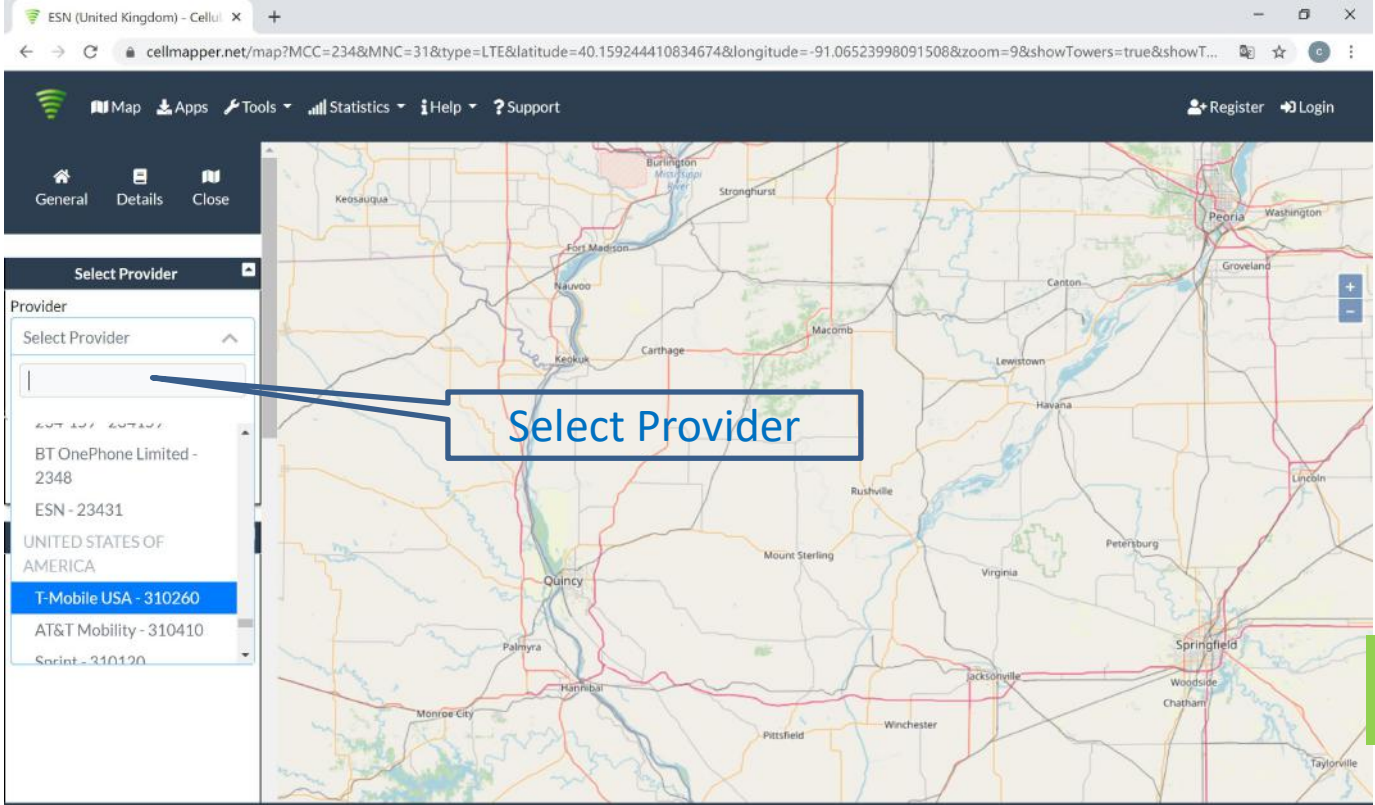

## Step 4: Find your cell tower

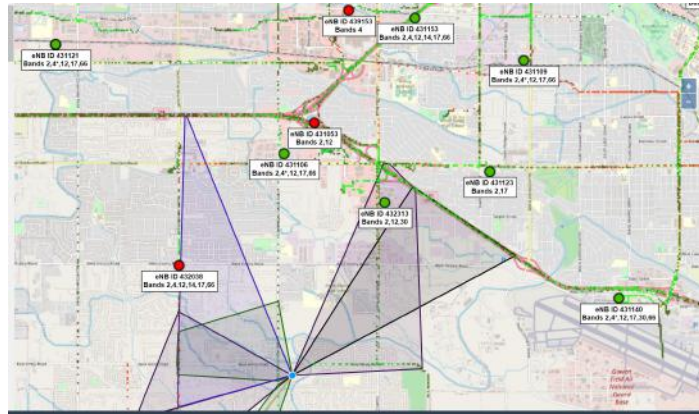
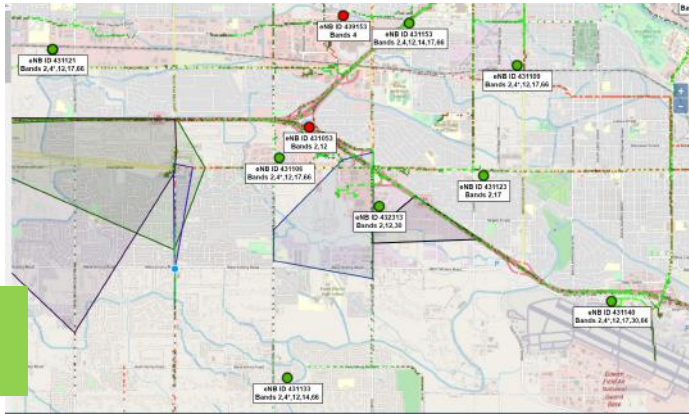
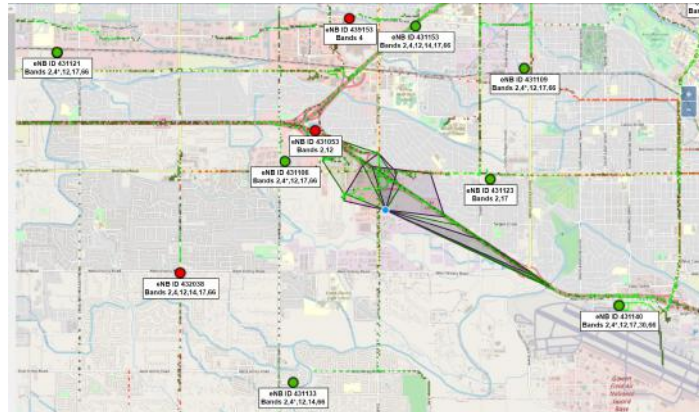
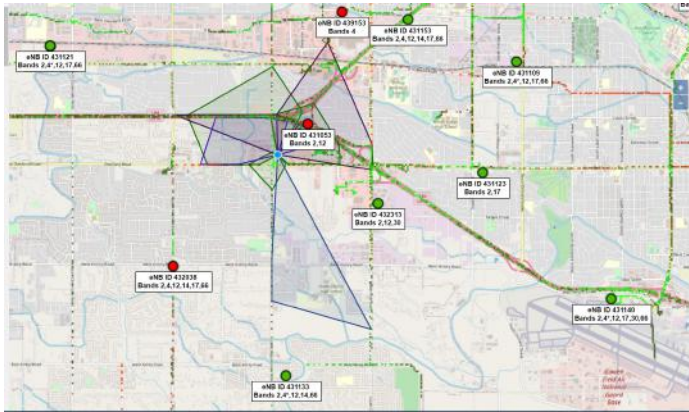

Click the red or green dot on the map that represents the base station, and the detailed information of the base station will be displayed.

- As you can see from the pictures, above the coverage area (colored shapes) of each antenna is different. Find an antenna with signal coverage overlapping your house, or the coverage direction is facing you and the coverage area is closest to you.

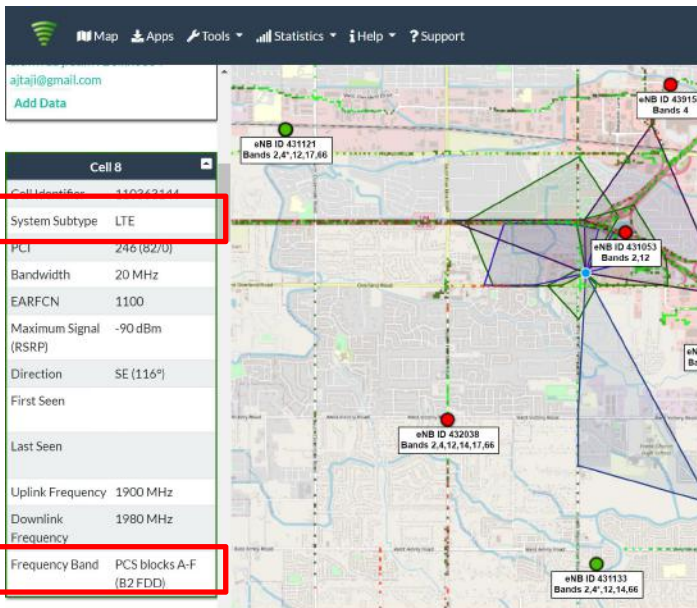

- You can scroll the information content on the left to find the specific carrier information of this antenna, including the communication standard and frequency band. Please reference the left picture, "LTE" and "B2 FDD" (Band 2, FDD).

## Find The dBm Reading On Your Phone

Having an accurate measurement of signal strength in decibels (dBm) is crucial when installing your system. Decibels accurately measure the signal strength you are receiving.

**Note:** Turn off your cell phone's WiFi to ensure you are checking the cellular connection. The dBm reading will be refreshed every 30-60 seconds. Want faster results? Once you have a reading, turn on airplane mode, wait 15 seconds, then turn off airplane mode. The signal strength reading will be refreshed.

**iPhone:** dial \*3001#12345#\* then press call

The image shows the iPhone dial pad with the code \*3001#12345#\* entered. A blue arrow points to the 'Main Menu' screen where 'Serving Cell Info' and 'Serving Cell Meas' are highlighted with a red box.

sel_plmn_mcc	302
ul_bw	100
sel_plmn_mnc	220
timestamp	2020-07-27 14:22:57 MDT
phy_cell_id	6
freq_band_ind	2
dl_bw	100
ul_freq	18900
num_mnc_digits	
dl_freq	

Band number

rsrp0	-107
rsrq0	-25
sinr0	10.0
rsrp1	-107
rsrq1	-27

Receive level dBm

**Android:** Download the third-party app Network Cell Info Lite

The screenshot shows the 'Network Cell Info' app interface. A gauge displays the signal strength as -98 dBm. A callout box points to the band number '66'.

Receive level dBm

Band number

We **STRONGLY** recommend doing a test installation before finalizing the installation. Doing a test installation of your cell phone booster ensures that you will get the optimal performance from your system.

### Step1: Select the Location for the Outside Unit

**Note:** This is the most critical step and will determine the overall performance of the booster system.

1. Generally, the strongest signal will be located on the side of your home facing the nearest cell tower. Keep in mind the signal strength at ground level may be different from the signal strength at or above the roof line due to obstructions (trees, other buildings, etc.) that block the incoming signal. In most situations, the strongest signal is found about 25 feet above the ground on the side of your home facing the nearest cell tower.
2. The most ideal installation position is the corner of the building, choose the one facing your cell tower.

**Four corner of the building are the most ideal position**

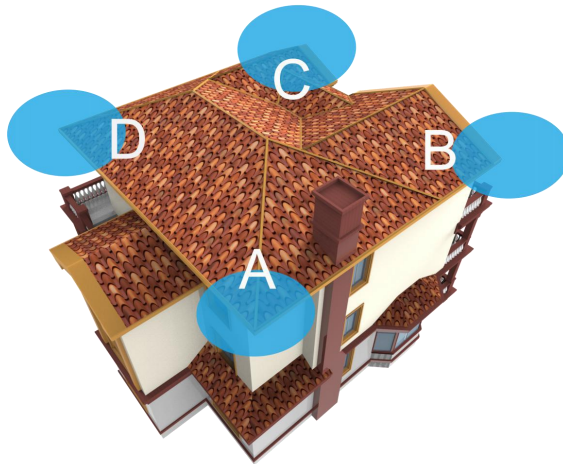

**Choose the one facing your cell tower**





## Step 2: Temporarily Mount the Outside Antenna

In addition to the four corners of the building, the chimney and the pole above the roof can also be selected. As long as the installation distance between indoor and outdoor antennas is maintained enough, satisfactory results can also be achieved.

Use one of the three options to mount the outside antenna on your roof on the side of the house with the strongest signal.

The height of the outside antenna should never exceed the highest point of your house. This is a precaution against damage and safety concerns caused by lightning strikes to the outside unit.



### Caution

Trees will greatly attenuate wireless signals if there are tall trees within 100 feet of the house. At the same time you can't find a stable signal above 3 bars, the outdoor antenna needs to be erected 60% (at least) to 80% (best) of the tree height. **Never exceed the trees!**

According to FCC regulations, outdoor antenna height cannot exceed 30 feet.

At the same time, if the antenna exceeds the roof, please pay attention to lightning protection measures.

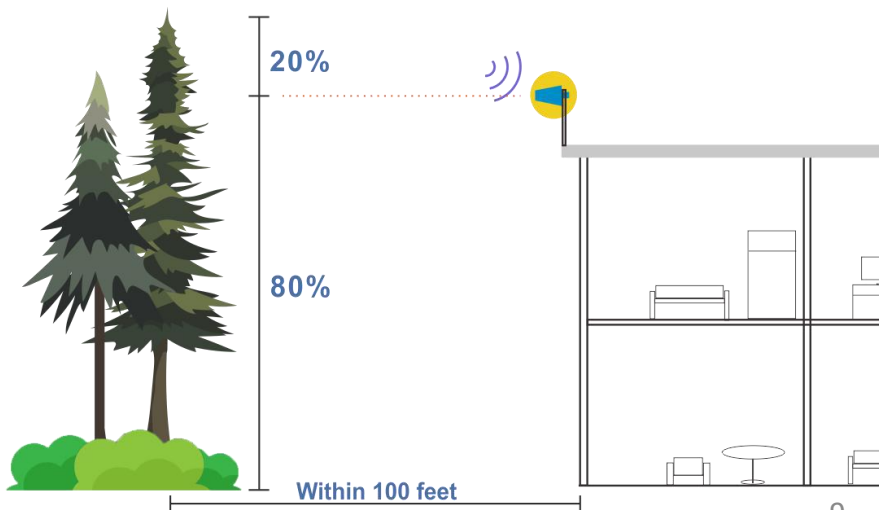

## Step3: Select the Location for the Inside Antenna

In order to achieve the best signal coverage effect, there is a certain distance requirement between the indoor and outdoor units. Make sure the inside and outside units are facing away from each other.

**Minimum Required Separation Distance Between Indoor and Outdoor Antenna:**  
**Straight line distance over 30 feet (10 meters)**  
**or 20 ft (6 meters) horizontal distance**  
**13 ft (4 meters) vertical distance (as far as possible)**

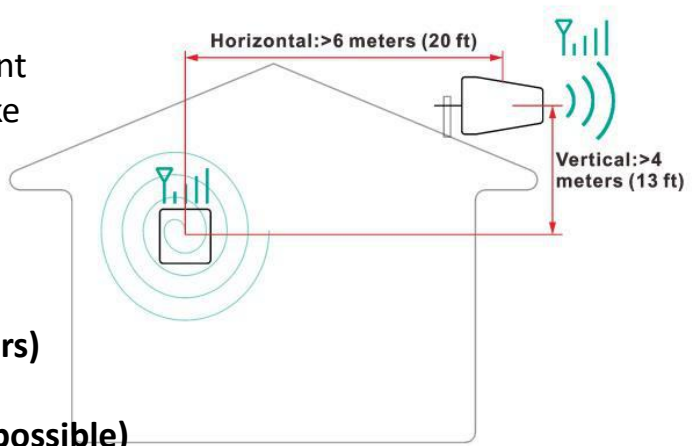

## Measure the Signal Strength Inside your Home

- Test your current signal strength in multiple locations throughout the home
- Record the current signal strength in the table provided for reference



No	Location	Record(dBm)
1		
2		
3		
4		

## Top view of antenna beam shape and energy distribution

- The radiation beam angle of indoor and outdoor antennas is about 90 degrees;
- In addition to signal radiation in front of the antenna, there is also energy radiation behind the antenna;

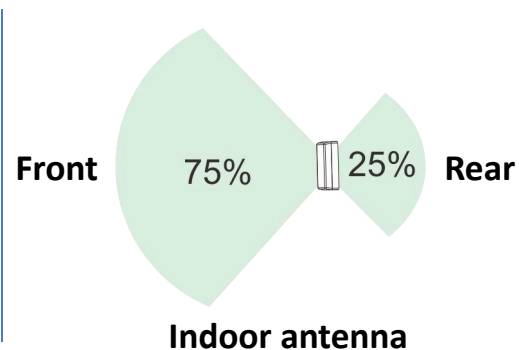
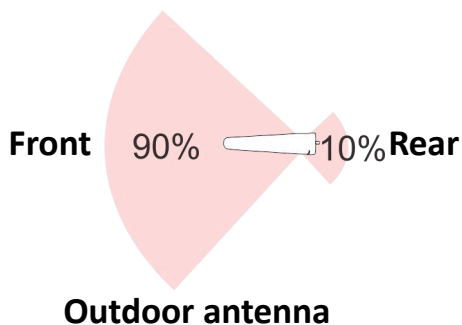

# Antenna mutual position( top view)

Avoid cross antenna beams (the best solution)

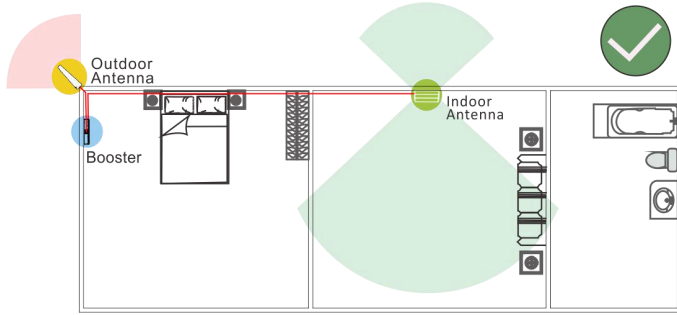

Ensure the distance, allow the antenna to cross the rear beam (good solution)

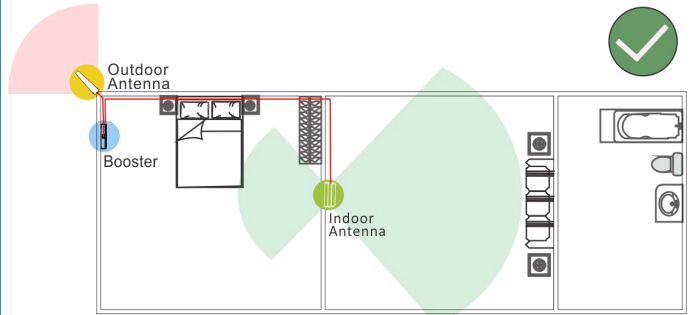

Do not face the outdoor antenna to the indoor antenna

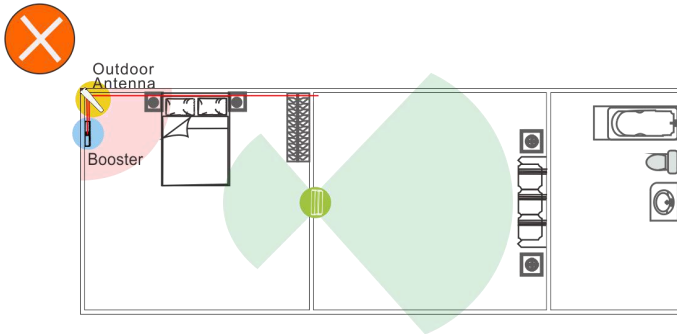

Do not face the indoor antenna to the outdoor antenna

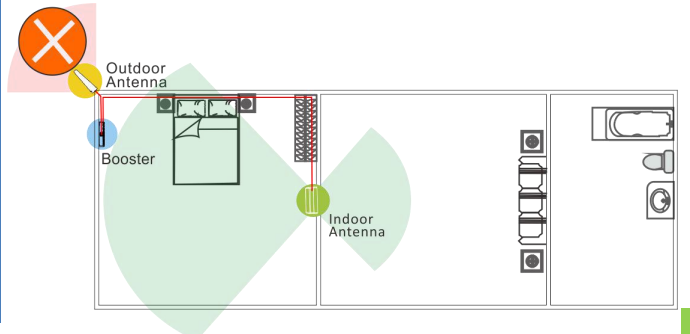

The indoor antenna is a panel directional antenna. Choosing a location facing the inside of your home will help to maximize your coverage area.



## Step4: Connect the System

1. Connect the outside antenna to the coax cable and secure the cable in order to avoid internal damage of the antenna connector due to gravity or pulling the cable

Secure the cable near the antenna to prevent cable damage caused by wind shaking



2. Connect the outside antenna to the "OUTSIDE" port of booster.



3. Connect the other coax cable to the booster at the "INSIDE" port.



4. If you have 2 inside antennas, connect the other end of the coax cable to splitter at the "INPUT" port, and two inside antennas' cables connect to the other side port.

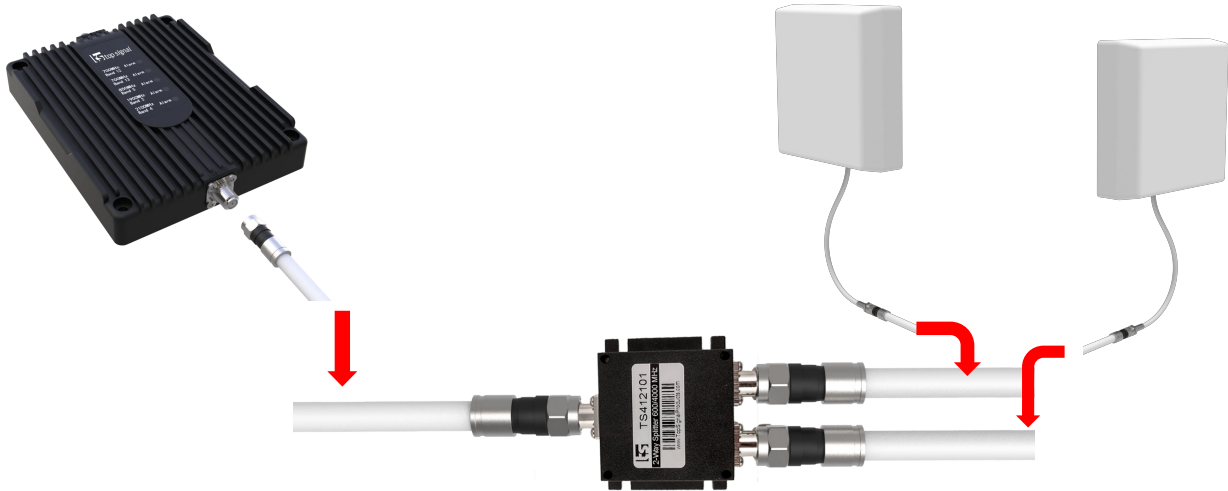

5. Connect the other end of the coax cables to the panel antennas.

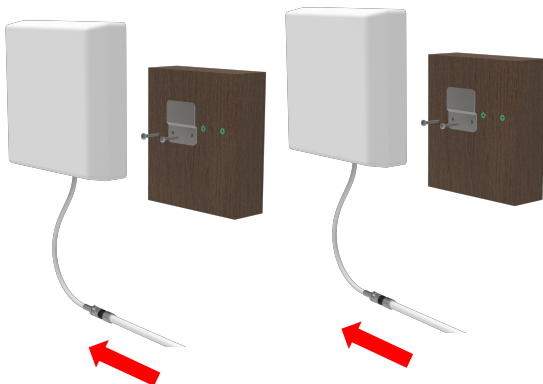

6. Plug in the power adaptor and connect it to the nearest power outlet (surge protector recommended).



## Step5: Evaluate the Effects

- Now that the booster is up and running, re-test the signal strength inside your home at the same locations from Step 1. If the number is higher (dBm reading is closer to zero) than the original reading, your booster is working.
- If your signal is not stronger, check the LED lights on the booster and refer to the “Quick Troubleshooting” section at the end of the manual.



No	Location	Record(dBm)
1		
2		
3		
4		

### Decibel Gain vs. Power Amplification/Distance/Coverage area

Decibel Gain	Power Amplification (times)	Distance Enhance (times)	Coverage Enhance (times)
6	4	2	4
10	10	3	9
20	100	8	64
30	1000	32	900

**Note:** Decibel Gain and Power Amplification may vary depending on the specifics of your situation. Different building materials and other obstructions in your home will result in different outcomes.

# Step6: Finalizing Outdoor Antenna Installation

Once you have tested the performance of the signal booster and made all necessary adjustments, it's time to finalize the installation.

## Outdoor Antenna Installation

Make sure that the outside unit is mounted at least 3 feet away from any windows.

**Option A : Outside Roof Pole Mount (Best Choice)** Use an existing pole to mount the outdoor unit in the optimal signal location. Use the picture for reference.

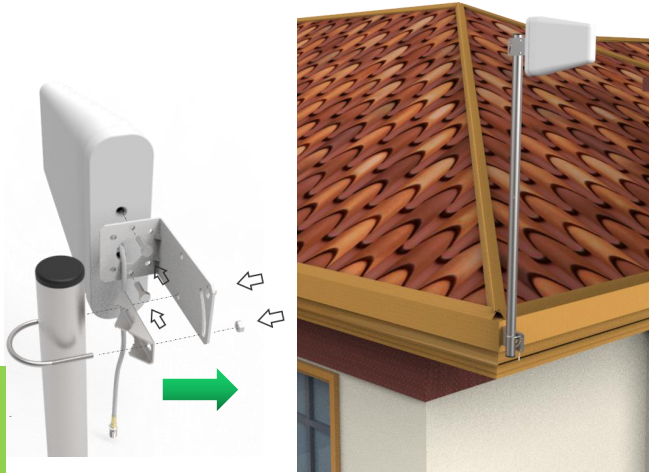

**Option B : Mounting on the side of the chimney(Second Choice).**

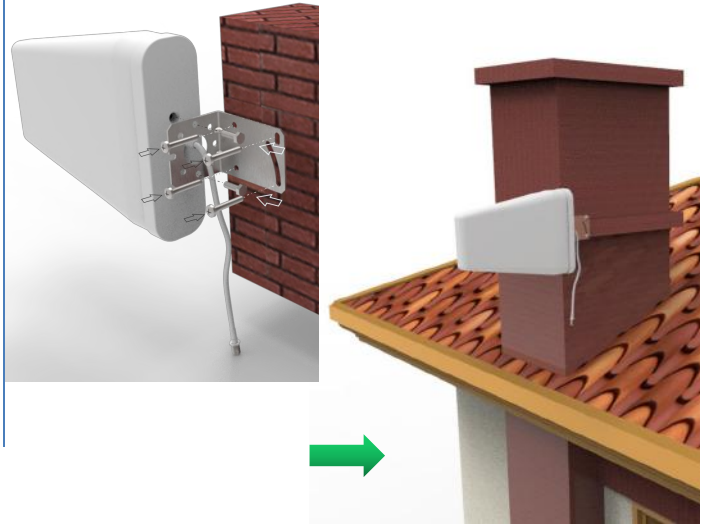

## Seal and Fix the Connector

Cables for outdoor antenna locations should be fixed, otherwise the internal wires of the cable will be pulled off by wind. The amplifier will not receive the signal and the system will fail completely.

 As shown in the figure, it is best to have the cable around a single turn shape and then fix it.

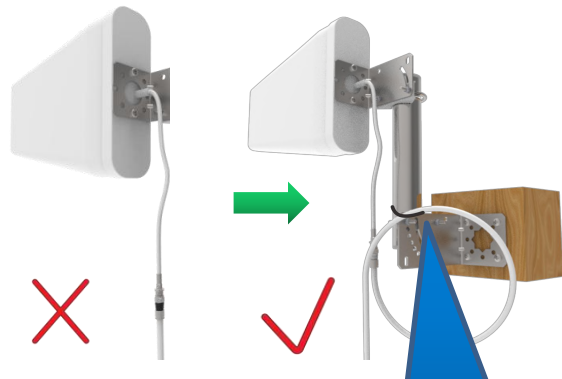

Secure the cable to prevent cable damage caused by wind shaking

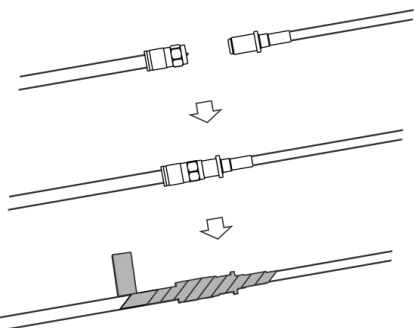

Long-term rain or moisture erosion can damage the electrical characteristics of outdoor antenna connectors. Make sure connectors are well screwed in and seal the connectors with glued tape.

## Step7: Finalizing Indoor Installation

- a. Choose right position for the indoor antenna
  - 20 cm away from facing any other metallic objects
  - 50 cm away from any windows
  - The inside antenna should be facing the location of the signal dead zone/weak signal area inside the building
- b. Mount the inside antenna
- c. Connect the inside cable to the inside antenna
- d. Mount the booster
  - Choose a ventilated and dry place
  - Keep away from heat
  - Don't cover booster

 Booster will about 30 degrees Fahrenheit higher than the ambient temperature, which is normal.

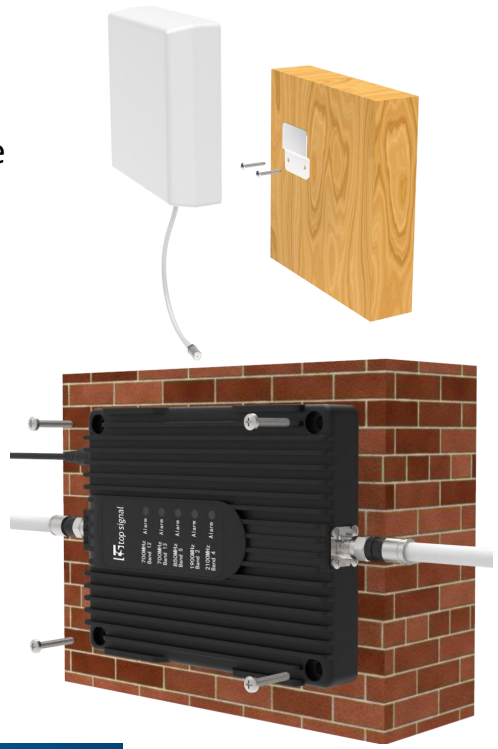

## Step8: Finalizing and Securing Cable Route

- Find the best route for the cable. Follow the lines of your home to hide the cable in eaves or between the soffit and the exterior wall.
- If needed, cable clips can be purchased at most hardware stores.
- Whether the cable is properly secured is very important for the entire system. In most cases, the customer found that the booster did not work after working for a period of time because the cable was not installed securely.
- Carefully arrange the cable along the outside of the building and ensure that there are no folds or kinks. Fix the cable at each corner.

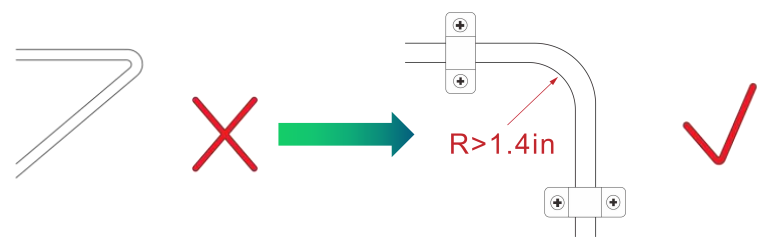

### Seal and Fix the Connector

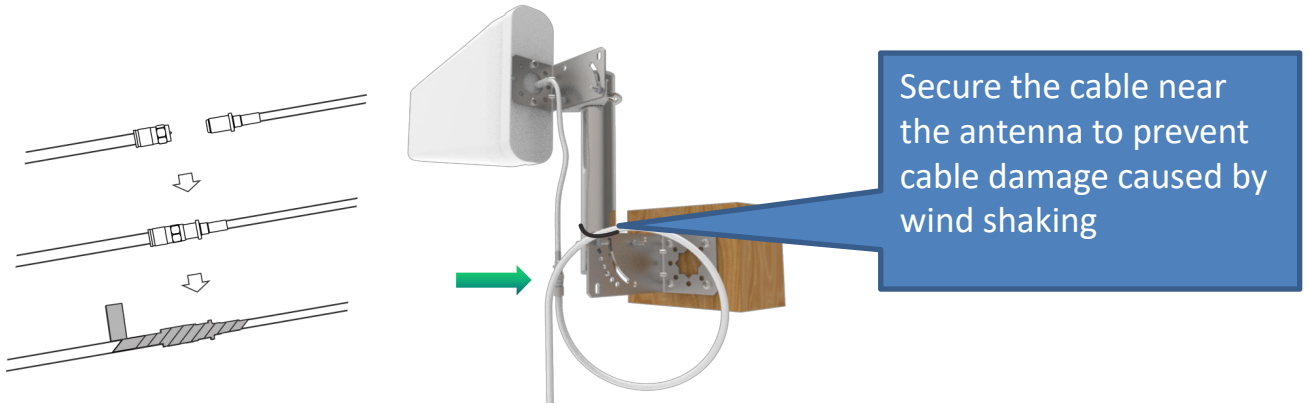

### Properly Handle Excess Cables

If the coiled cable is too close to the antenna or booster, the system will be unstable. Make sure these coiled cables are more than 6 feet (2 meters) from the antenna or booster

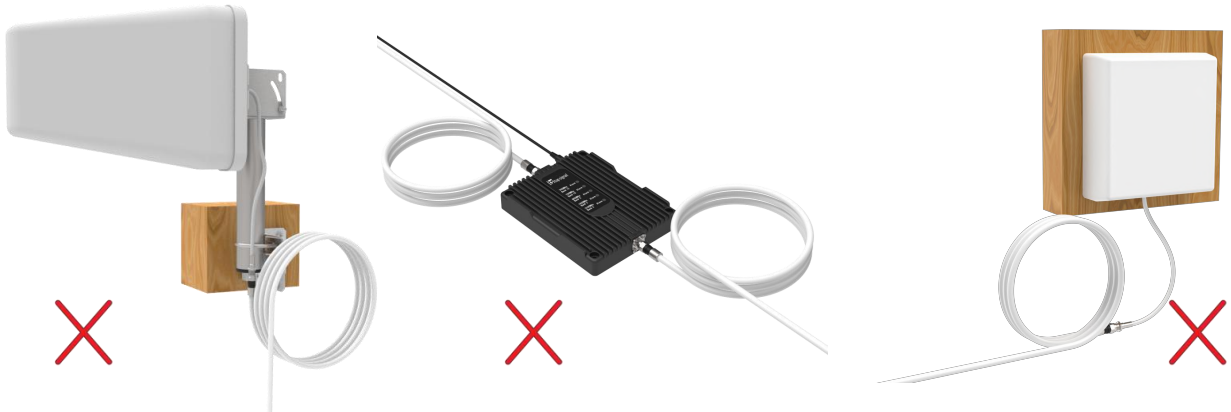

Make sure these excess coiled cables are more than 6 feet (2 meters) from the antenna or booster can make your system work more stable.

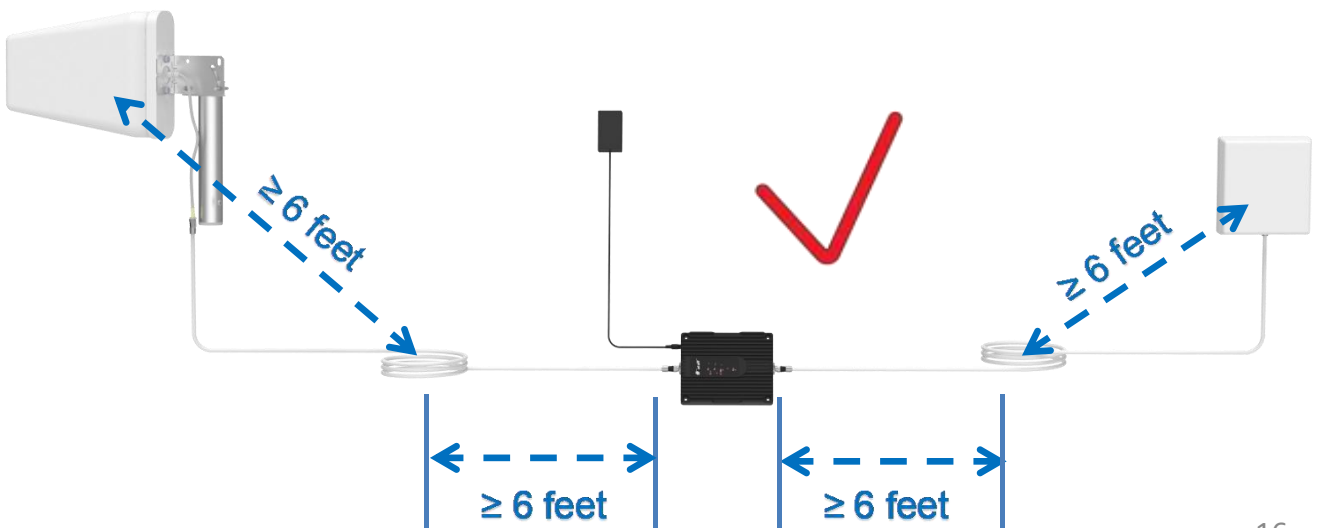



# Quick Trouble shooting

## Correct functioning:

- Power light should be solid white (the logo on the panel)
- The indicator light on the front panel indicates the status of the booster. Every time the booster is turned on, all the indicators will turn green briefly and then go out. This means that the booster has passed the self-check and is in good condition.



Power Light

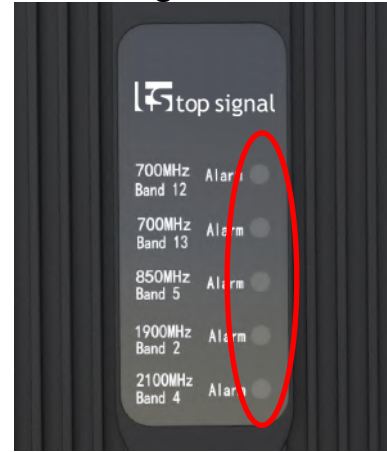

Panel State Light

## Trouble Shooting: No Signal Improvement

Step 1. Check power. Ensure the indoor unit is plugged in and the LED Power Light is lighting.

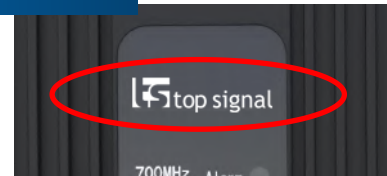

Step 2. Check cable connections. Ensure the indoor and outdoor units are securely connected to the coax cable.

Step 3. Check incoming signal level at outdoor unit position. Usage of a booster is not recommend when the outdoor signal is less than  $-110\text{dbm}(3\text{G}/1\text{x})$  or  $-120\text{dBm}(4\text{G}/\text{LTE})$ .



Step 4. Check your outdoor antenna direction is facing the tower which coverage your house

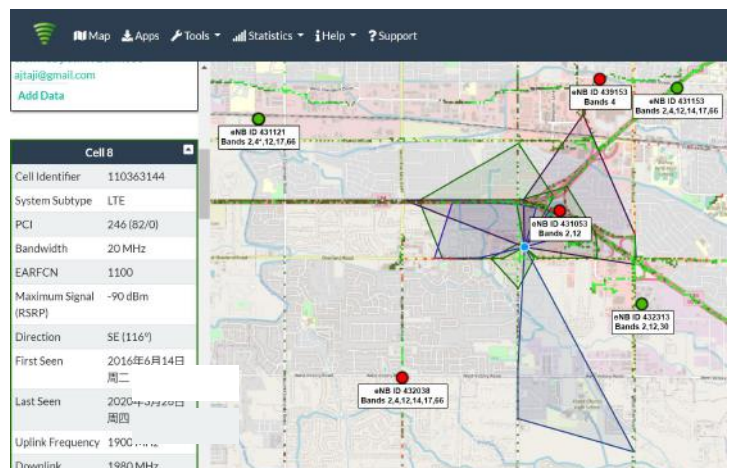

Step 5. Trees will greatly attenuate wireless signals if they are tall and within 100 feet of the house. At the same time you can't find a stable signal above 3 bars, the outdoor antenna needs to be erected 60% (at least) to 80% (best) of the tree height. **Never exceed the trees!**

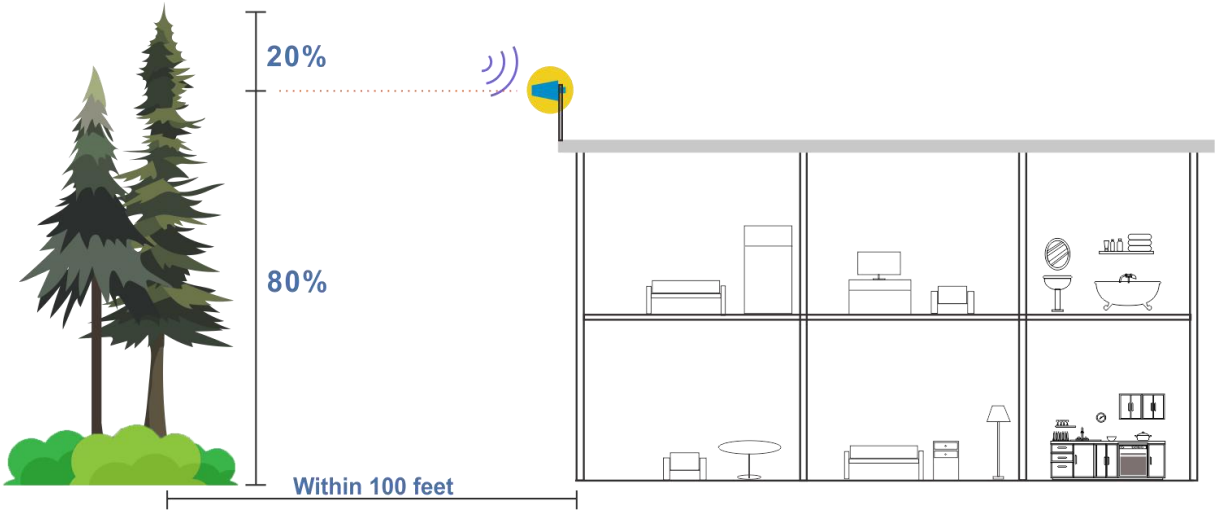

Step 6. If any of the lights on the front panel are flashing in green then off/continue flashing/solid green, it means that self oscillation is occurring. You must switch off the booster and check the outside and inside antennas' separation immediately. Make sure that the Minimum Separation Requirements have been met. Make sure that the outside antenna is not pointed towards the inside antenna.

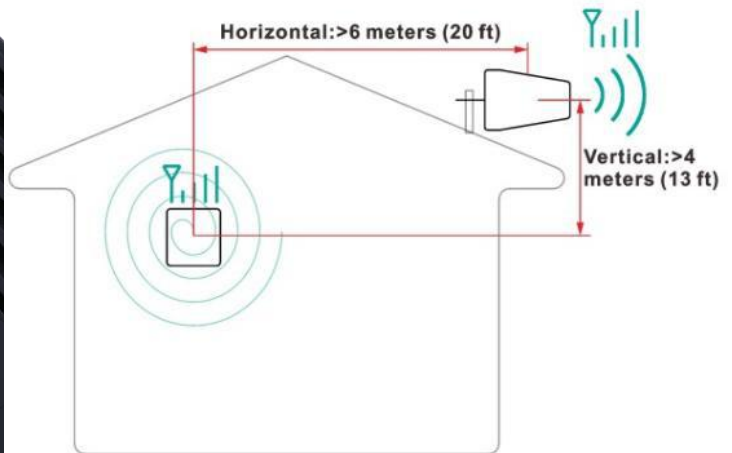
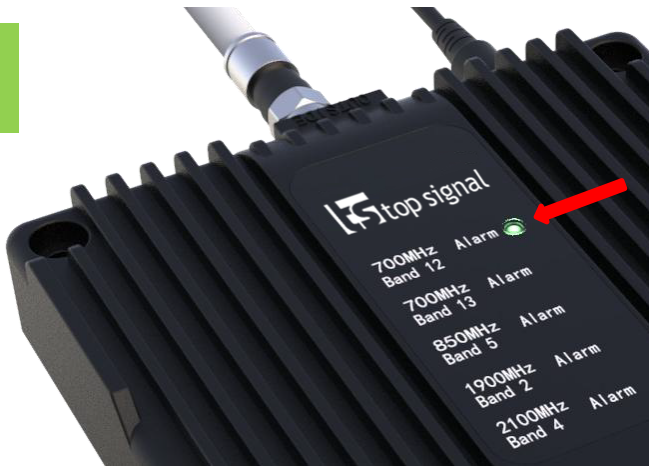

**Minimum Required Separation Distance Between Indoor and Outdoor Antenna:**  
Straight line distance over 30 feet (10 meters)  
or 20 ft (6 meters) horizontal distance  
13 ft (4 meters) vertical distance (as far as possible)

Frequency (MHz)		LTE (band 12)	LTE (band 13)	Cellular (band 5)	PCS (band 25/2)	AWS (band 4)
	Uplink	698-716	776-787	824-849	1850-1915	1710-1755
	Downlink	728-746	746-757	869-894	1930-1995	2110-2155
Gain	Uplink	62	62	62	65	65
	Downlink	65	65	65	68	68
Output power	23dBm(Uplink)/6dBm(Downlink)					
Noise figure	<5dB					
In-band Flatness	<9dB					
Weight	0.65Kg					
EIRP	1W					
Impedance	50 ohm					
Operating temperature	5°F to 140°F (-15°C~60 °C)					
Current	≤1.5A(12V DC)					
Dimension(mm/in)	158*125*25/6.2*4.87*0.98					

## WARRANTY



The Booster is covered under a three-year product warranty for failures or defects that result from craftsmanship and/or materials. Dated proof of purchase should be retained for use in warranty cases. Contact Powerful Signal with any warranty issues. The product may be returned with a dated proof of purchase and a return authorization letter which can be attained by contacting Powerful Signal.

This warranty does not apply to any signal booster components determined by Powerful Signal to have been subjected to misuse, abuse, neglect, tampering, or mishandling that result in damages to the physical or electronic properties of the product.

**DISCLAIMER:** The information provided by Powerful Signal is believed to be complete and accurate, to the best of our knowledge. However, no responsibility is assumed by Powerful Signal for any business or personal losses arising from the use of the information herein contained, or for any infringements of patents or other rights of third parties that may result from its use.

## Safety Guidelines

To uphold network protection standards and ensure compliance, all active cellular devices must maintain a separation distance of at least six feet between the inside unit antenna and outside unit antenna and at least four feet of separation distance from the inside unit. Use only the power supply provided in this package. Use of a non-Top Signal product or accessory may result in damage to the equipment or components of the equipment. The inside unit is designed for use in an indoor, temperature-controlled environment (less than 100 degrees Fahrenheit). It is not intended for use in attics or similar locations where temperatures may be in excess of that range.

RF Safety Warning: Any antenna used with this device must be located at least 8 inches from all persons.

### This is a **CONSUMER** device

**BEFORE USE**, you **MUST REGISTER THIS DEVICE** with your wireless provider and have your provider's consent. Most wireless providers consent to the use of signal boosters. Some providers may not consent to the use of this device on their network. If you are unsure, contact your provider.

In Canada, **BEFORE USE** you must meet all requirements set out in ISED CPC-2-1-05. You **MUST** operate this device with approved antennas and cables as specified by the manufacturer. Antennas **MUST** be installed at least 20 cm (8 inches) from (i.e., **MUST NOT** be installed within 20 cm of) any person.

You **MUST** cease operating this device immediately if requested by the FCC (or ISED in Canada) or licensed wireless service provider.

**WARNING.** E911 location information may not be provided or may be inaccurate for calls served by using this device.

This device complies with Part 15 of FCC rules. Operation is subject to two conditions: (1) This device may not cause harmful interference, and (2) this device must accept any interference received, including interference that may cause undesired operation. Changes or modifications not expressly approved by Powerful Signal could void the authority to operate this equipment.

FOR MORE INFORMATION ON REGISTERING YOUR SIGNAL BOOSTER WITH YOUR WIRELESS PROVIDER, PLEASE SEE BELOW:

Sprint <https://www.t-mobile.com/support/coverage/register-a-signal-booster>  
T-Mobile/MetroPCS: <https://www.t-mobile.com/support/coverage/register-a-signal-booster>  
Verizon Wireless: <https://www.verizon.com/solutions-and-services/accessories/register-signal-booster/>  
AT&T: <https://securec45.securewebsession.com/attsignalbooster.com/>  
U.S. Cellular: <https://www.uscellular.com/support/fcc-booster-registration>

If you have any questions or concerns when installing or operating your cell phone booster, please email us at [sales@powerfulsignal.com](mailto:sales@powerfulsignal.com) or call us at (435) 634-6800.