

# Fusion4Home Max

*Cellular signal booster kit for the Home or Office*

## User Guide



Thank you for purchasing SureCall's Fusion4Home Max cellular signal booster kit. SureCall's Fusion4Home Max was specifically designed to eliminate frustrations over dropped calls and limited range by amplifying incoming and outgoing cellular signals in homes and offices.

If you have any questions during setup, please reach out to our US-based experienced support technicians:

Call: 1-888-365-6283

Email: [support@surecall.com](mailto:support@surecall.com)

Visit: [www.surecall.com/support](http://www.surecall.com/support)



Watch installation, optimization and troubleshooting techniques on our SureCall YouTube channel



[@SureCall](https://twitter.com/SureCall)



Stay up to date with all things SureCall

## TABLE OF CONTENTS

How it works .....	4
PACKAGE CONTENTS.....	4
BEFORE INSTALLATION.....	5
Installation Overview .....	6
INSTALLATION .....	6
Step 1. Find the Area With the Strongest Signal.....	6
Step 2. Install the Outside Yagi Antenna and Outside Amplifier.....	7
Step 3. Install the Inside Amp and Inside Antenna.....	7
Step 4: Connect to Power and Turn On.....	10
Check and Optimize System, If Needed .....	11
IF YOU WANT TO IMPROVE PERFORMANCE.....	11
Performance Optimization.....	11
TROUBLESHOOTING .....	11
LED INDICATORS.....	12
SPECIFICATIONS.....	13
Kitting .....	14
Configuration .....	15
CONSUMER GUIDELINES.....	16
WARRANTY .....	17
Three-Year Product Warranty .....	17

## How it works

1. The high-gain outside antenna captures even the weakest cell signal, from the cell tower where it is aimed.
2. The Fusion4Home Max outside booster uses Extended Range Technology™ (ERT) to grab signal outside, at its strongest point, where it boosts voice, text and data signals for all 4G & 5G devices.
3. Using low-loss RG-6 cable, signal is transmitted from the outside to the Fusion4Home Max inside host amplifier.
4. The signal is then broadcast from the inside panel antenna to all cellular devices in range.
5. The Fusion4Home Max system also works in reverse, boosting the outgoing signal and to faraway and hard-to-reach towers.

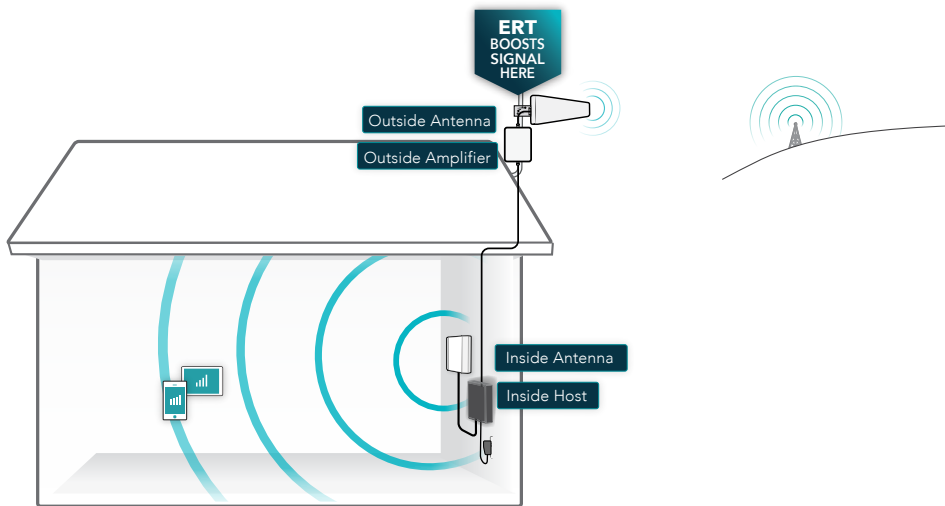

*How the SureCall Fusion4Home Max Works*

## PACKAGE CONTENTS

Unpack all package contents. For missing or damaged items, contact your reseller.

Turn over the signal booster and record the model and serial number for reference:

Serial #: \_\_\_\_\_

Purchase Date: \_\_\_\_\_

Keep the carton and packing material to store the product in case you need to return.

Your Fusion4Home Max signal booster package includes the following items:

1



*Outside Yagi antenna  
and mounting bracket*

2



*Fusion4Home Max  
Outside Amplifier  
and mounting bracket*

3



*Outside Cable  
(75 ft)*

4



*Fusion4Home Max inside  
host amplifier*

5



*Power supply*

6



*Inside Cable  
(20 ft)*

7



*Inside panel antenna  
and mounting bracket*

## BEFORE INSTALLATION

Before you begin, note the following information

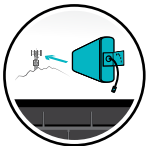

### **YOUR EXPECTED BOOSTER PERFORMANCE AND COVERAGE AREA IS DETERMINED BY THE SIGNAL RECEIVED BY YOUR OUTSIDE ANTENNA.**

Where you position your outside antenna will help overcome weak signals for better performance. Ideally, position the outside antenna up high, aimed towards your nearest cell tower in order to catch the best signal. NOTE: The weaker your outside signal, the more limited your coverage will be indoors.

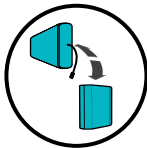

### **BETTER ANTENNA SEPARATION MEANS BETTER PERFORMANCE**

Maintain a distance of at least vertical 25 feet, up to 50 feet of horizontal distance, especially if vertical separation cannot be achieved. Also, make certain the antennas are aimed away from one another.



### **YOUR CELL PHONE BARS ARE NOT AN ACCURATE MEASURING TOOL**

Cell phone bars are an approximation of your signal that varies by phone and carrier. During installation and testing, always take multiple readings several minutes apart. Also, verify that you can place and hold a call.

Warning: Changes or modifications not expressly approved by SureCall could void the user's authority to operate the equipment.

## Installation Overview

Before installation, review the above information.

In addition to the contents listed below, you will need a ladder, drill, cable clips, and a pole or mast to mount your outside components. A mounting pole is available separately (SC-MOUNT-JBAR), if needed. Prior to securing the location of any booster parts, a “soft install” is recommended as adjustments may be needed to optimize performance.

**Step 1.** Find the outside area with the strongest signal.

**Step 2.** Install the outside yagi antenna and outside amp in the location identified in step 1.

**Step 3.** Install the inside panel antenna and connect the inside host unit.

**Step 4.** Connect power source and turn on.

**Step 5.** Test system performance and optimize configuration as needed.

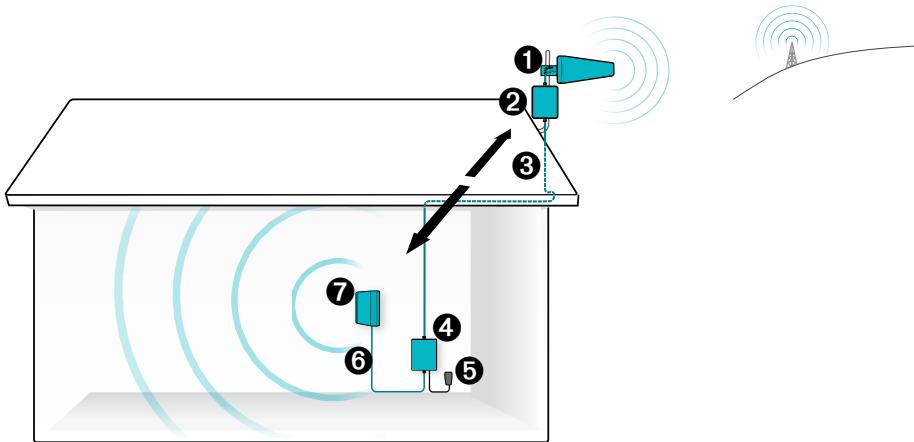

## INSTALLATION

### Step 1. Find the Area With the Strongest Signal

Identify the outside location with the strongest signal for placement of your outdoor yagi antenna. This is generally found on the side facing your nearest cell tower and as high as possible -- where the antenna can ‘see’ your cell tower.

For help locating your closest cell tower, you may utilize an app such as ‘Open Signal’ or go to [www.antennasearch.com](http://www.antennasearch.com).

**Please note,** The coverage area that the booster provides is directly related to the strength of incoming signal received by the outdoor antenna. Mounting the outside antenna where the signal is the strongest provides the best results. If signal is extremely weak where the outside antenna is installed, indoor coverage will be limited. Bars are not always a reliable measure of signal. The best way to confirm signal coverage is the ability to place and hold a call.

**For more detailed measurements**, you can take readings of your phone's signal in decibels(dB). Decibels are measured in the negatives and generally should fall between -40 and -130. A score closer to zero indicates a stronger signal. For example, a signal of -120 dB indicates no service, while a score of about -50 dB means you have excellent signal.

For specific dB signal measurements, use the methods below.

- iOS - First turn off your Wi-Fi, Next, open the Phone app and dial \*3001#12345#\* then press the call button. This will open the Field Test app. Once open, menu navigation varies depending on iOS version, as well as, carrier and iPhone model; however these instructions should get you to the right place.
  - iOS 14 and later: Navigate to LTE in the menu list then tap on Serving Cell Meas. The measurements that read "rsrp0" and "rsrp1" are your cellular signal strength in decibel-milliwatts.
  - If you're using an earlier version of iOS, we have more information available here: <https://blog.surecall.com/enter-field-test-mode-on-iphone-or-android-phones/>
- Android devices: Download the app "Network Signal Info" in the Google Play store.

## Step 2. Install the Outside Yagi Antenna and Outside Amplifier

Once you have identified the area of strongest signal, choose where you will mount your outside antenna and outside amplifier while considering the following factors:

1. The mounting area must have at least a 3 ft radius clear of obstructions, other radiating elements and metal objects such as pipes or metal siding.
2. Both components should be mounted on a pole or pipe (not provided), at the highest possible location above the roofline – at least 25 vertical feet above the planned location for the indoor antenna.

Note there are two main outside components -- a Yagi directional antenna and the outside amplifier.

## Step 3. Install the Inside Amp and Inside Antenna



*Outside Yagi antenna and mounting bracket*



*Fusion4Home Max outside amplifier and mounting bracket*



*Outside Cable (75 ft)*

Warning: Do not collocate antennas or operate the outdoor antenna with any other antenna or signal booster.

## Install the Yagi antenna

Once you have identified your install location, assemble the u-bolt, bracket, nuts and washers onto a pole (available separately) as shown in the illustration.

Keep the connections loose enough to allow the antenna to rotate until the optimum direction is found.

Orient the antenna with the drip hole at the bottom.

## Place the Outside Amplifier

Next assemble the bracket for the outside amplifier the same way you did the yagi bracket and secure in the same location within range of the antenna cable connection.

Connect the yagi cable connector to the outside amplifier as shown here.

With both components in place, connect one end of the provided 75 ft. coax cable to the outside amplifier and hand tighten the connection.

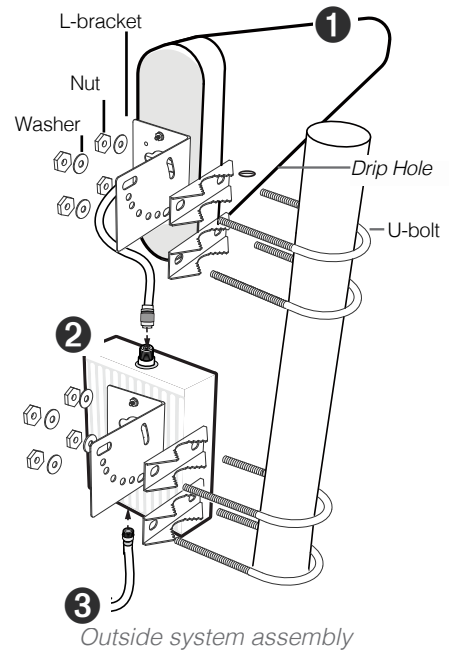

### IMPORTANT:

Take caution during installation to not aim these antenna towards the other antenna

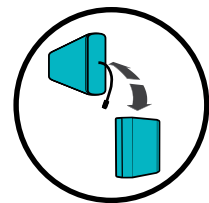

*Aiming Directional Antennas*



Choose a location for the booster and inside antenna that is near a working outlet and at least 25 Ft from the outside antenna. Consider the below factors affecting booster performance.

1. Signal strength at the location of the outside antenna.
2. Interior building materials between the inside antenna and your mobile device.
3. Distance between the outside antenna and inside antenna (minimum 25 ft. separation)
4. Ensure inside antenna points away from the outside antenna.



Panel Antenna



Inside cable



Inside host amp



power supply

Note: This booster should not be used near open fire or flame. Storage and transportation: Store and place in non-extreme room-temperature and dry environment.

### Install the Panel Antenna

SureCall's Inside panel antennas are directional with a 120° reach. They should be mounted facing the area signal is needed and away from the outdoor antenna (See "Aiming Directional Antennas" on page 8).

Mount on a vertical surface that is the approximate height of normal cell phone use. The antenna may be concealed behind a wall provided there are no materials that could obstruct signals.

Besides the antenna itself, parts include mounting equipment for a flat horizontal surface.

1. Using plate, mark position of desired screw placement.
2. Screw mounting plate into place with the slide panel protruding towards you.
3. Slide antenna securely onto mounting plate.

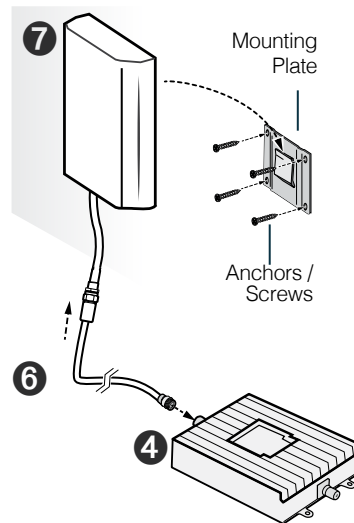

## Place the Inside Host

The inside host amp may be placed on a flat surface or mounted to a wall. Choose a location that is near a working AC outlet. To install the booster to a wall, use the supplied screws or appropriate screws for surface and drill through screw tab holes on booster (see *"Host Unit Diagram"* illustration).

Connect the panel antenna to the inside host amp port marked INSIDE using the 20 ft of SC-240.

Next, connect the outside and inside components by routing the RG-6 outside cable from the outside amplifier indoors and connect to the booster port marked "OUTSIDE".

## Step 4: Connect to Power and Turn On

Connect the AC power cord to the booster and plug into a 110V AC power outlet. Once the booster has been completely assembled, turn the booster's power switch to ON.

Note: If the Power LED does not turn ON or the Alert LEDs continue to flash, see the "Troubleshooting" on page 11 section.

Note: This booster is rated for 5-15V input voltage. DO NOT use the booster with a higher voltage power supply. This can damage the booster, cause personal injury, and void your warranty.

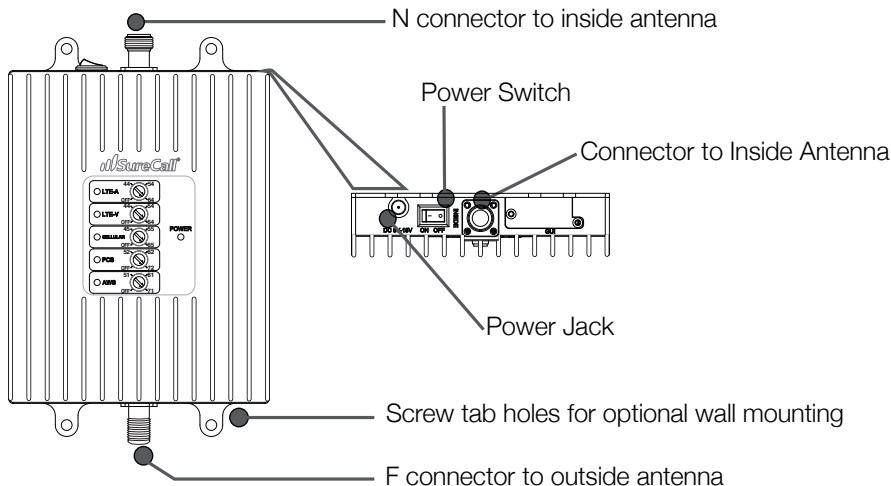

*Host Unit Diagram*

## Check and Optimize System, If Needed

Place a call in the room where the inside antenna is located to confirm that your phone is receiving a boosted signal.

Note: Bars are not always a reliable measure of signal. The best way to confirm signal coverage is the ability to place and hold a call.

Only the presence of a RED/YELLOW flash indicates the presence of an unresolved issue.

Important: The booster gain dials should remain at maximum level and only reduced if other recommended actions do not resolve the issue.

## IF YOU WANT TO IMPROVE PERFORMANCE

### Performance Optimization

The Fusion4Home Max automatically reduces gain (coverage performance) because of insufficient RF Separation between the inside and outside antennas.

Consider the following options to resolve issues with inadequate antenna isolation.

1. Verify that a minimum distance of 25 vertical feet has been achieved. Separation up to 50 ft of horizontal distance may be needed, however, especially where vertical separation is not possible.
2. Check for sources of interference such as, cellular modems or hotspots.
3. Verify neither antenna is placed near a window.
4. Ensure that the antennas are aimed away from one another.

## TROUBLESHOOTING

If you have any questions during setup, please reach out to our US-based experienced support technicians:

Call: 1-888-365-6283

Email: [support@surecall.com](mailto:support@surecall.com)

Visit: [www.surecall.com/support](http://www.surecall.com/support)

Problem	Resolution
Signal booster has no power	Connect the power supply to an alternate power source. Verify that the power source is not controlled by a switch that has removed power from the outlet. If it remains OFF, contact tech support at: <a href="tel:1-888-365-6283">1-888-365-6283</a> or <a href="mailto:support@surecall.com">support@surecall.com</a>
After completing installation, indoor signal coverage has not improved	Verify that cable connections are tightly fitted to the booster and antenna. Try further separating the booster and antenna. Verify that there is usable signal where the antenna is placed. Note: Bars are not always a reliable measure of signal. The best way to confirm signal coverage is the ability to place and hold a call.

## LED INDICATORS

Note: Bars are not always a reliable measure of signal. The best way to confirm signal coverage is the ability to place and hold a call.

Only the presence of a RED/YELLOW alternate flash indicates the presence of an unresolved issue that requires action

Important: The booster gain dials should remain at maximum level and only reduced if all other recommended actions do not resolve the issue.

LED Condition	Status/Resolution
Initializing on Power-up	All control lights flash RED & YELLOW for 5 seconds then off for 5 minutes.
GREEN SOLID	Normal Operation
GREEN FLASHING	Normal Operation.
YELLOW SOLID	Normal Operation, Sleep Mode
YELLOW FLASHING Slowly	AGC has detected Insufficient separation between the inside and outside antenna automatically reduced gain by 1 - 10 dB for the indicated frequency band. This may be unavoidable in some situations where distance cannot be achieved. After 5 minutes the frequency control light will return to SOLID GREEN
YELLOW FLASHING Quickly	AGC has detected significant antenna isolation issues causing a reduction in gain between 10 and 20 dB for the indicated frequency band(s). Adjustments should be made to improve your booster's performance by following suggested methods under "Performance Optimization". After 5 minutes the frequency control light will return to SOLID GREEN
RED / YELLOW FLASHING Alternately	Extreme gain reduction (greater than 20 dB) resulting from insufficient antenna separation. The frequency band has been disabled. Adjustments are required to resolve condition. Follow the suggested methods under "Performance Optimization".
RED SOLID	Indicates the frequency band is manually turned off.

Keep in mind, identifying the setup that yields the best possible results for your environment will come from testing -- balancing the elimination of interference and while also receiving the best possible signal.

## SPECIFICATIONS

<b>Model</b>	<b>Fusion4Home Max (US and Canada)</b>
Uplink Frequency Range (MHz):	698-716 / 776 – 787 / 824-849 / 1850-1915 / 1710-1755
Downlink Frequency Range (MHz):	728-746 / 746 – 757 / 869-894 / 1930-1995 / 2110-2155
Maximum Gain:	72 dB
Supported Standards:	CDMA, WCDMA, GSM, EDGE, HSPA+, EVDO, LTE and all cellular standards
Max Uplink Power:	26.0 dBm
Input Impedance:	50Ω
VSWR	≤2.0
Noise Figure:	<8 dB
AC Input:	Input AC110V, 60 Hz; Output DC 5-15V
Maximum Output Power:	1 Watt EIRP
Cable:	RG6 (75 ft) / SC-240 (20 ft)
RF Connectors:	F-Female inside / N-Female outside
Power Consumption:	≤25W
Operation Temperature (°F):	4° to +158°(Outside Amp); -4° to +104° (Inside host) for optimal performance
<b>Fusion4Home Max Outside Amp</b>	
Dimensions:	7.87 x 4.96 x 1.22 in
Weight:	1.85 lb
Certifications	FCC ID: RSNF4H-MAX; IC : 7784A-F4HMAX
<b>Fusion4Home Max Inside Host</b>	
Dimensions:	8.05 x 5.22 x 1.46 in
Weight:	1.90 lb
Certifications	FCC ID: RSNF4H-MAXS; IC : 7784A-F4HMAXS

## Kitting

Component	Product number	Gain/Loss					Note
		LTE-A 707 MHz	LTE-V 731 MHz	Cellular 800 MHz	PCS 1900 MHz	AWS 1700 / 2100 MHz	
Outdoor Antenna*	SC-268W	5.5dBi	5.5dBi	6dBi	7.5dBi	7.5dBi\8dBi	
	SC-232W	8.5dBi	8.5dBi	8.5dBi	8.5dBi	8.5dBi\8.5dBi	
Cable between systems *	SC-RG6 -50 (50')	3.32dB	3.32dB	3.75dB	6.42dB	6.22dB\6.68dB	50 to 150 Feet
Inside Cable*	SC-240-20NN (20')	2.06 dB	2.06 dB	2.29 dB	3.56 dB	3.36 dB / 3.76 dB	20 Feet or longer
Inside Antenna*	SC-248W	7dBi	7dBi	7dBi	10dBi	10dBi\10dBi	For Panel-RT
	SC-222W	3dBi	3dBi	3dBi	6dBi	6dBi\6dBi	
	SC-121W	1.2dBi	1.2dBi	1.2dBi	3dBi	3dBi\3dBi	
	SC-302W	2.5dBi	2.5dBi	3dBi	5dBi	4dBi\5dBi	
	SC-323W	2.5dBi	2.5dBi	3dBi	4dBi	4dBi\4dBi	For Flare-RT
* All equivalent antennas and cables are suitable for use with the Fusion4Home RT 1.0							

**FCC 15.105 Statement** This equipment has been tested and found to comply with the limits for a Class B digital device, pursuant to part 15 of the FCC Rules. These limits are designed to provide reasonable protection against harmful interference in a residential installation. This equipment generates, uses and can radiate radio frequency energy and, if not installed and used in accordance with the instructions, may cause harmful interference to radio communications. However, there is no guarantee that interference will not occur in a particular installation. If this equipment does cause harmful interference to radio or television reception, which can be determined by turning the equipment off and on, the user is encouraged to try to correct the interference by one or more of the following measures:

- Reorient or relocate the receiving antenna
- Increase the separation between the equipment and receiver.
- Connect the equipment into an outlet on a circuit different from that to which the receiver is connected
- Consult the dealer or an experienced radio/TV technician for help.

**15.19** This device complies with Part 15 of the FCC Rules. Operation is subject to the following two conditions: (1) this device may not cause harmful interference, and (2) this device must accept any interference received, including interference that may cause undesired operation

**Warning:** Any product modifications that use unauthorized antennas, cables, and/or coupling devices are prohibited by the FCC. Contact FCC for details: 1-888-CALL-FCC. Changes or modifications not expressly approved by SureCall could void the user's authority to operate the equipment.

Note: The term "IC" before the radio certification number only signifies that Industry Canada technical specifications were met.

**FCC 27.50(d)(4) Statement:** Fixed, mobile and portable (hand-held) stations operating in the 1720-1755 MHz band are limited 1 Watt EIRP. Fixed stations operating in this band are limited to a maximum antenna height of 10 meters above ground. Mobile and portable stations operating in this band must employ a means for limiting power to the minimum necessary for successful communications.

# Configuration

Pre AGC				Pre AGC		
Pulse GSM				4.1 MHz AWGN		
Frequency (MHz)	Input (dBm)	Output (dBm)	Gain (dB)	Input (dBm)	Output (dBm)	Gain (dB)
UL 1710-1755	-43.2	19.7	62.9	-42.6	20.0	62.6
UL 1850-1915	-42.4	21.3	63.7	-43.4	19.0	62.4
UL 824-894	-38.7	21.0	59.7	-38.8	19.9	58.7
UL 698-716	-36.8	21.1	57.9	-35.9	21.0	56.9
UL 776-787	-40.3	18.2	58.5	-38.6	20.1	58.7
DL 2110-2155	-59.9	8.9	68.8	-62.4	7.1	69.5
DL 1930-1995	-56.4	10.1	66.5	-59.2	8.4	67.6
DL 869-894	-51.0	10.3	61.3	-52.0	9.0	61.0
DL:728-746	-50.9	10.1	61.0	-53.3	8.6	61.9
DL 746-757	-52.9	8.7	61.6	-54.2	7.5	61.7

# CONSUMER GUIDELINES

## This is a CONSUMER device

**BEFORE USE**, you **MUST REGISTER THIS DEVICE** with your wireless provider and have your provider's consent. Most wireless providers consent to the use of signal boosters. Some providers may not consent to the use of this device on their network. If you are unsure, contact your provider.

In Canada, **BEFORE USE** you must meet all requirements set out in ISED [CPC-2-1-05<sup>1</sup>](#)

You **MUST** operate this device with approved antennas and cables as specified by the manufacturer. Antennas **MUST** be installed at least 20 cm (8 inches) from (i.e. **MUST NOT** be installed within 20 cm of) any person.

You **MUST** cease operation of this device immediately if requested by the FCC (or ISED in Canada) or a licensed wireless service provider.

**WARNING:** E911 location information may not be provided or may be inaccurate for calls served by using this device.

This device may be operated **ONLY** in a fixed location, for in-building use.

## Ce produit est un appareil de CONSOMMATION

**AVANT DE L'UTILISER**, vous **DEVEZ ENREGISTRER CE DISPOSITIF** auprès de votre fournisseur de services cellulaires et obtenir son consentement. La plupart des fournisseurs de services cellulaires autorisent l'utilisation d'amplificateurs de signal. Il se peut que certains fournisseurs n'autorisent pas l'utilisation de ce dispositif sur leur réseau. Si vous n'êtes pas sûr, contactez-le.

Au Canada, **AVANT DE L'UTILISER** vous devez répondre à toutes les exigences ISED [CPC-2-1-05<sup>2</sup>](#)

Vous **DEVEZ** utiliser ce dispositif avec les antennes et les câbles autorisés, tel que le spécifie le fabricant. Les antennes **DOIVENT** être installées à au moins 20 cm (8 po) (**NE DOIVENT PAS** être installées à moins de 20 cm) de toute personne avoisinante.

Vous **DEVEZ** arrêter cet appareil immédiatement à la demande de la FCC (ISED au Canada) ou de tout fournisseur de services cellulaires autorisé.

**AVERTISSEMENT:** Il se peut que les informations relatives à la localisation E911 ne soient pas disponibles ou soient inexactes pour les appels qui utilisent cet appareil.

Cet appareil peut fonctionner seulement à un emplacement fixe à l'intérieur d'un bâtiment;

Register your cellular booster with your wireless carrier at the following urls:

**Verizon:** <http://www.verizonwireless.com/wcms/consumer/register-signal-booster.html>

**AT&T:** <https://securec45.securewebsession.com/attsignalbooster.com/>

**T-Mobile:** <https://support.t-mobile.com/docs/DOC-9827>

**Sprint:** [https://www.sprint.com/legal/fcc\\_boosters.html](https://www.sprint.com/legal/fcc_boosters.html)

**U.S. Cellular:** <http://www.uscellular.com/uscellular/support/fcc-booster-registration.jsp>

## CAN ICES-3 (B)/NMB-3(B) (Canada) :

This Class B digital apparatus meets all requirements of the Canadian Interference Causing Equipment Regulations. Operation is subject to the following two conditions: (1) this device may not cause harmful interference, and (2) this device must accept any interference received, including interference that may cause undesired operation

The Manufacturer's rated output power of this equipment is for single carrier operation. For situations when multiple carrier signals are present, the rating would have to be reduced by 3.5 dB, especially where the output signal is re-radiated and can cause interference to adjacent band users. This power reduction is to be by means of input power or gain reduction and not by an attenuator at the output of the device.

Cet appareillage numérique de la classe B répond à toutes les exigences de l'interférence canadienne causant des réglemets d'équipement. L'opération est soumise aux deux conditions suivantes: (1) ce dispositif peut ne pas causer l'interférence nocive, et (2) ce dispositif doit accepter n'importe quelle interférence reçue, y compris l'interférence qui peut causer l'opération peu désirée.

La puissance de sortie nominale indiquée par le fabricant pour cet appareil concerne son fonctionnement avec porteuse unique. Pour des appareils avec porteuses multiples, on doit réduire la valeur nominale de 3,5 dB, surtout si le signal de sortie est retransmis et qu'il peut causer du brouillage aux utilisateurs de bandes adjacentes. Une telle réduction doit porter sur la puissance d'entrée ou sur le gain, et ne doit pas se faire au moyen d'un atténuateur raccordé à la sortie du dispositif.

1 For details on the requirements specified in ISED CPC-2-1-05, visit: <http://www.ic.gc.ca/eic/site/smt-gst.nsf/eng/sf08942.html>

2 Pour plus de détails sur les exigences ISED CPC-2-1-05, reportez-vous au site: <http://www.ic.gc.ca/eic/site/smt-gst.nsf/eng/sf08942.html>



# WARRANTY

## Three-Year Product Warranty

To activate your three-year manufacturer's warranty, register at [www.SureCall.com/activate](http://www.SureCall.com/activate)

SureCall warrants its products for three years from the date of purchase against defects in workmanship and/or materials. Specifications are subject to change. The three-year warranty only applies to products meeting the latest FCC Certification Guidelines stated on 2/20/2013 and going into effect April 30, 2014. A two-year warranty applies to any products manufactured before May 1, 2014.

Products returned by customers must be in their original, un-modified condition, shipped in the original or protective packaging with proof-of-purchase documentation enclosed, and a Return Merchandise Authorization (RMA) number printed clearly on the outside of the shipping container.

Buyers may obtain an RMA number for warranty returns by calling the SureCall Return Department toll-free at 1-888-365-6283. Any returns received by SureCall without an RMA number clearly printed on the outside of the shipping container will be returned to sender. In order to receive full credit for signal boosters, all accessories originally included in the signal booster box must be returned with the signal booster. (The Buyer does not need to include accessories sold in addition to the signal booster, such as antennas or cables.)

This warranty does not apply to any product determined by SureCall to have been subjected to misuse, abuse, neglect, or mishandling that alters or damages the product's physical or electronic properties.

SureCall warrants to the Buyer that each of its products, when shipped, will be free from defects in material and workmanship, and will perform in full accordance with applicable specifications. The limit of liability under this warranty is, at SureCall's option, to repair or replace any product or part thereof which was purchased up to THREE YEARS after May 1, 2014 or TWO YEARS for products purchased before May 1, 2014, as determined by examination by SureCall, prove defective in material and/or workmanship. Warranty returns must first be authorized in writing by SureCall. Disassembly of any SureCall product by anyone other than an authorized representative of SureCall voids this warranty in its entirety. SureCall reserves the right to make changes in any of its products without incurring any obligation to make the same changes on previously delivered products.

As a condition to the warranties provided for herein, the Buyer will prepay the shipping charges for all products returned to SureCall for repair, and SureCall will pay the return shipping with the exception of products returned from outside the United States, in which case the Buyer will pay the shipping charges.

The Buyer will pay the cost of inspecting and testing any goods returned under the warranty or otherwise, which are found to meet the applicable specifications or which are not defective or not covered by this warranty.

Products sold by SureCall shall not be considered defective or non-conforming to the Buyer's order if they satisfactorily fulfill the performance requirements that were published in the product specification literature, or in accordance with samples provided by SureCall. This warranty shall not apply to any products or parts thereof which have been subject to accident, negligence, alteration, abuse, or misuse. SureCall makes no warranty whatsoever in respect to accessories or parts not supplied by it.

### Limitations of Warranty, Damages and Liability:

EXCEPT AS EXPRESSLY SET FORTH HEREIN, THERE ARE NO WARRANTIES, CONDITIONS, GUARANTEES, OR REPRESENTATIONS AS TO MERCHANTABILITY, FITNESS FOR A PARTICULAR PURPOSE, OR OTHER WARRANTIES, CONDITIONS, GUARANTEES, OR REPRESENTATIONS, WHETHER EXPRESSED OR IMPLIED, IN LAW OR IN FACT, ORAL OR IN WRITING.

SURECALL AGGREGATE LIABILITY IN DAMAGES OR OTHERWISE SHALL NOT EXCEED THE PAYMENT, IF ANY, RECEIVED BY CELLPHONE-MATE, INC. FOR THE UNIT OF PRODUCT OR SERVICE FURNISHED OR TO BE FURNISHED, AS THE CASE MAY BE, WHICH IS THE SUBJECT OF CLAIM OR DISPUTE. IN NO EVENT SHALL SURECALL BE LIABLE FOR INCIDENTAL, CONSEQUENTIAL, OR SPECIAL DAMAGES, HOWSOEVER CAUSED.

All matters regarding this warranty shall be interpreted in accordance with the laws of the State of California, and any controversy that cannot be settled directly shall be settled by arbitration in California in accordance with the rules then prevailing of the American Arbitration Association, and judgment upon the award rendered may be entered in any court having jurisdiction thereof. If one or more provisions provided herein are held to be invalid or unenforceable under applicable law, then such provision shall be ineffective and excluded to the extent of such invalidity or unenforceability without affecting in any way the remaining provisions hereof.

SureCall has made a good faith effort to ensure the accuracy of the information in this document and disclaims the implied warranties of merchantability and fitness for a particular purpose and makes no express warranties, except as may be stated in its written agreement with and for its customers. SureCall shall not be held liable to anyone for any indirect, special or consequential damages due to omissions or errors. The information and specifications in this document are subject to change without notice.

© 2018. All Rights Reserved. All trademarks and registered trademarks are the property of their respective owners.

SureCall, Inc  
48346 Milmont Drive  
Fremont, California 94538, USA  
888.365.6283 | [www.surecall.com](http://www.surecall.com)