

**HiBOOST** Boost Your Bars

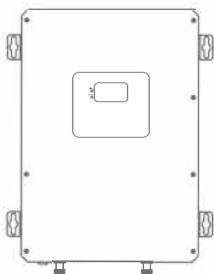

# User Manual

F27K-6S-IoT

Mobile Signal Booster



## TABLE OF CONTENT

TABLE OF CONTENTS .....	2
OPERATION .....	3
PACKAGE CONTENTS .....	3
KEY FEATURES .....	5
HOW TO INSTALL THE SIGNAL BOOSTER .....	5
1.1 Overview .....	5
1.2 Installation Preparation .....	5
1.3 How to find the location with the strongest received signal .....	6
1.4 Install Outdoor Antenna .....	8
1.5 Install Indoor Antenna .....	9
1.6 Install the signal booster .....	10
1.7 Run coaxial cable .....	10
1.8 Power up your signal booster .....	11
1.9 Booster Commissioning .....	11
SIGNAL BOOSTER STATUS .....	12
Port description .....	14
LCD Status .....	14
LED Status .....	16
Control Buttons Operation and Manual gain control (MGC) .....	17
Network Status .....	18
TROUBLESHOOTING .....	19
FCC RF EXPOSURE STATEMENT .....	20
IC RF EXPOSURE STATEMENT .....	21
WARNING AND STATEMENT .....	21
SPECIFICATIONS .....	22
PRODUCT WARRANTY .....	23

### ABBREVIATIONS and PHRASES USED IN THIS MANUAL

ALC: Automatic Level Control

DL: Downlink (Signal transmitted from local cell site tower to phone)

UL: Uplink (Signal transmitted from phone to cell site tower)

MGC: Manual Gain Control

dBm: The power ratio in decibels (dB) of the measured power referenced to one milliwatt (mW).

'Slow Flashing': Less than one flash per second

'Fast Flashing': More than one flash per second

## OPERATION

This manual covers operation, installation and troubleshooting procedures for the bi-directional amplifier Model: F27K-6S-IoT.

The F27K-6S-IoT amplifier is designed to help wireless device users amplify weak signals of all the major carriers in the 2G, 3G and 4G ,5G bands. This bi-directional amplifier is used to boost uplink signals from the phone to the local cell site tower and simultaneously amplify downlink signals transmitted from the tower to the phone. An antenna located outdoors (donor antenna) receives signals from the cell site tower, transmits them to the amplifier and then rebroadcasts them to antennas located indoors to the wireless device. The indoor antennas also receive signals transmitted from the phone that are boosted in the amplifier and sent to the tower via the outdoor donor antenna.

## PACKAGE CONTENTS

No.	Name	Description	Quantity
1	F27K-6S-IoT Amplifier		1
2	Power Supply Plastic	12V/8.5A	1
3	Expansion Bolt Tapping	Φ8	5
4	Screw	M6*50	4
5	User Manual		1



F27K-6S-IoT Booster



12V/8.5A  
AC/DC Power Supply

\* Outdoor and indoor antennas and cables are required for installation (purchased separately).

The F27K-6S-IoT industrial amplifier requires outside and inside antennas connected with appropriate coaxial cables and a splitter network. The F27K-6S-IoT can typically power 8-15 indoor antennas but the exact number of antennas, length of cable or other accessories needed can vary according to the size and construction of materials used in the building, outdoor signal strength and layout of the structure. Please contact us for assistance in designing your system.



### Multiple Antenna Installation Sample

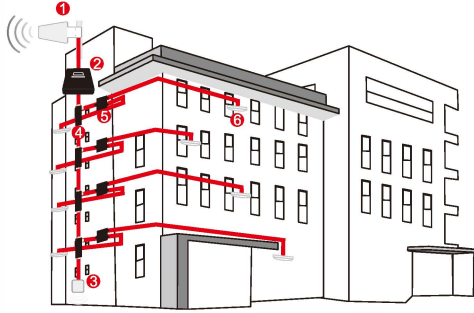

- 1.Outdoor Wide Band Directional Antenna 2. Booster 3. Indoor Wide Band Panel Antenna  
4.Coupler 5. Splitter 6. Indoor Wide Band Dome Antenna

### Optional Accessories Recommended



RF Cables



Outdoor Wide Band Directional Antenna



Outdoor Wide Band Panel Antenna



Outdoor Wide Band Post/OMNI Antenna



Indoor Wide Band Panel Antenna



Indoor Wide Band Dome Antenna



Whip Antenna



Lightning Surge Protector



Directional Coupler



Cavity Splitter (2,3,4 way)



Wilkinson Splitter (2,3,4 way)

## KEY FEATURES

- **Self-adaptive Smart Level Control (ALC):** Enables convenient 'plug and play' installation and optimum coverage in complex and dynamically changing RF signal environments.
- **ISO:** Smart isolation gain processing to avoid self-oscillation between antennas and avoid interference to the carrier network.
- **LCD Display:** Displays ISO status, ALC status, actual gain and downlink output power in each band to enable easy installation and troubleshooting.
- **MGC:** Manual Gain Control adjustments to independently change gain for both the uplink and downlink, 31dB range.
- **Excellent RF Performance:** 27 dBm downlink power available to overcome loss in long cable runs and splitter networks.
- **Low Profile Enclosure:** Light weight compact wall-mount with low power consumption and heat dissipation.

## HOW TO INSTALL THE SIGNAL BOOSTER

### 1.1 Overview

This manual will help you properly install your signal booster. It is important to read through all of the installation steps before installing your equipment. Thoroughly read through the instructions, visualize where all the equipment will need to be installed and do a soft installation by placing the devices where they need to be before mounting any equipment.

### 1.2 Installation Preparation

#### Before you install

- Make sure you have sufficient cable length between the proposed outdoor/indoor antennas and the amplifier.
- Make sure the mounting location is near an existing electrical outlet, well ventilated, away from excessive heat, moisture, and direct sunlight.

#### Tools Required



Phillips Screwdriver



Drill



Mobile Phone

No.	Name	Specification	Quantity	Remark
1	Plastic Expansion Bolt	Φ8	5	Standard accessories
2	Tapping Screws	M6*50	4	Standard accessories
3	Electric Drill		1	
4	Drill Bit		1	

**Before you get started**, you will need to plan the layout of your system. This involves finding the location with the strongest received signal from the cellular tower, as well as antenna, booster, and cable placement.

**General installation steps:**

1. Find the strongest received signal for the location of the outdoor antenna.
2. Install the outdoor antenna on the roof to obtain the strongest downlink signal from the local cellular towers. It should also be as far away as possible from where you plan to place the indoor antenna (vertical separation is more important than horizontal separation).
3. Install the indoor antennas where you want to improve the signal level.
4. Mount the booster, connect the cables from the outdoor antenna and indoor antenna at the designated ports, and connect the booster to the AC supply (make sure all the cables are connected before applying power).

**1.3 How to find the location with the strongest received signal**

The outdoor signal strength the booster receives directly affects the efficiency of the indoor coverage. That is why it is crucially important to install the antenna at a good location and point it properly towards a tower where signal reception is the strongest.

There are many methods that can be used to find the strongest signal from the cellular towers. One is to use the LCD display on the booster that shows the downlink power output of the booster in each band, the other is to use a mobile phone or mobile phone app to test signal strength, and the third is to use a commercially available signal strength meter.

We highly recommend that you use the LCD display on the booster as this method is generally more convenient. However, in situations where the desired carrier's signal is much weaker than the other local signals, using a mobile phone, app or signal level meter can be a more accurate method of homing in

on the best signal for installation.

- **LCD Display Method**

Connect the outdoor antenna to the booster's outdoor port. Fix the outdoor antenna on the roof of the building and point it to the nearest cell tower. Then have a look at the gain and output power value displayed on the amplifier's LCD.

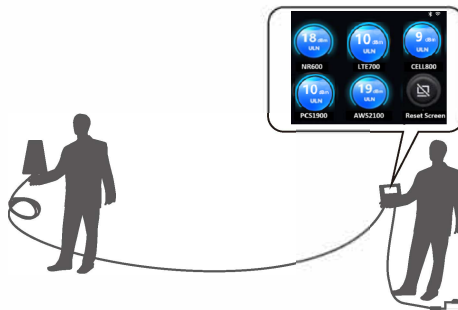

The outdoor antenna receives the strongest signal when the booster's downlink output power reaches its highest level in each band. If the LCD shows maximum gain and power, and there are not any alarms (no OSC, ALC, SHUTDOWN showing and no quick flashing green or red in LED), it means the present location is the best for ensuring that the booster has maximized performance.

The maximum downlink power for F27K-6S-IoT is 27dBm, and the maximum downlink gain is 85dB.

**Note:** These showed values may vary dynamically at times between 1-3 dB which is normal due to outdoor signal conditions.

When the gain value is reduce and no band is on OSC status , it means the received signal power is stronger than the system needs it to be. It is recommended to adjust the outdoor antenna orientation until the Gain is at max value(85dB). Or you can leave it as it is to let the booster self-adjust automatically. However, when the ALC function is engaged , and the displayed gain is 42dB less than the amplifier's rated max gain value, try to adjust the outdoor antenna to decrease the received signal power from the local tower. Otherwise it may be necessary to install an attenuator on the outdoor antenna port to decrease the input signal level from the local tower.

- **Mobile Phone Method**

You can use a telephone to test signal strength on the top of the building. The number of bars on the network indicator will define approximate strength of the received signal. Normally the roof of the building is the best place to receive the strongest signal. As shown on the drawing below, you need to test the signal in the points from A to E, and select the location with the best signal strength for outdoor installation. It is recommended to use a mobile app that can display in a test mode the signal level in dBm units. It is more accurate than checking the



signal bars. For more details refer to <https://www.hiboost.com/blog/>

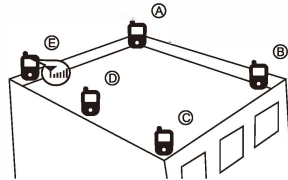

**Note:** Please try to receive a signal from cell towers that are not overloaded with multiple users. This can be estimated by the population density in the area served by the tower. For example, it is recommended to avoid cell towers near supermarkets, shopping malls, stadiums or any other public places visited by many people regularly. This will help maintain reliable phone call connections and higher speed data services.

Mark the strongest received signal as the installation location and direction for the outdoor antenna.

### 1.4 Install Outdoor Antenna

Install the outdoor antenna at the location with the strongest received signal. In most cases an outdoor wide band directional or panel antenna is the best outdoor antenna choice.

**IMPORTANT:** Testing the signal 3 times in the desired location before installing the outdoor antenna will help ensure the most smooth and stable phone calls and data transmission.

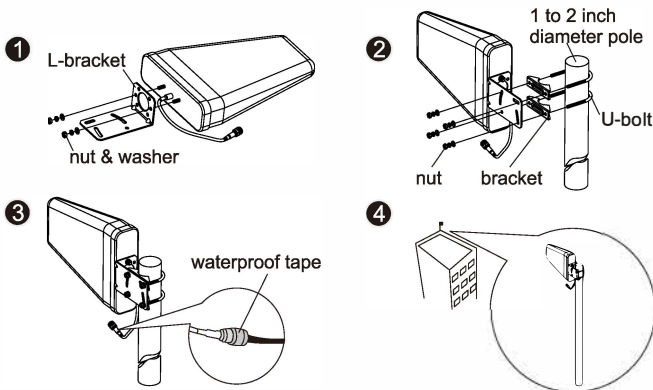

Outdoor wide band directional antenna installation for reference



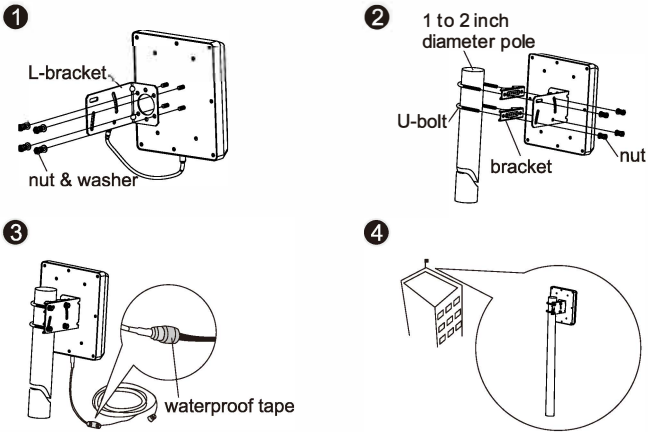

Outdoor wide band panel antenna installation for reference

**Note:** Be sure the cradle is at the desired height and rotated toward the strongest cellular signal before tightening the nuts. Do not over tighten. Wrap waterproof tape around the connectors between outdoor antenna and feeder line to avoid moisture ingress.

### 1.5 Install Indoor Antenna

Select indoor wide band panel antenna or indoor wide band dome antenna as an indoor antenna according to your needs to provide indoor coverage. Select a place on a wall in the area where you need better reception. Mount the indoor antenna with the included screws as shown in the figure below.

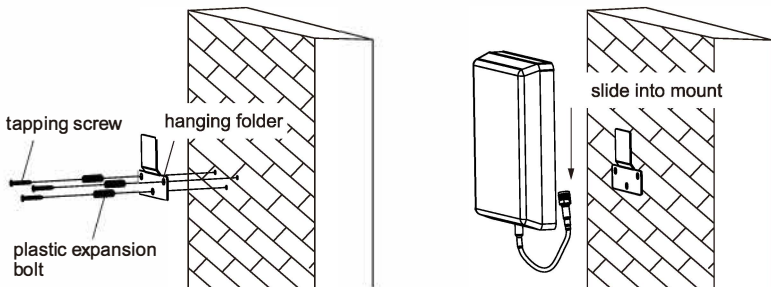

Indoor wide band panel antenna installation for reference



When choosing an indoor wide band dome antenna, the best place to install it is in the center of area that needs signal improvement. Install the dome antenna as shown on the figure below:

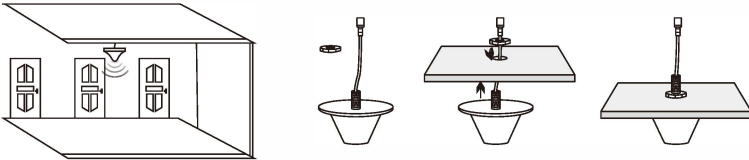

Indoor wide band dome antenna installation for reference

## 1.6 Install the signal booster

The signal booster should be mounted in an easily accessible area so it's easy to perform general maintenance. The area is properly ventilated and not exposed to excessive heat, moisture and/or direct sunlight. The optimal area would be on a wall located near a power outlet. Please use a surge protector rated at a minimum of 1000 Joules between the booster's power adaptor and the AC power outlet on the wall.

Mount the booster with the included screws as shown in the figure below.

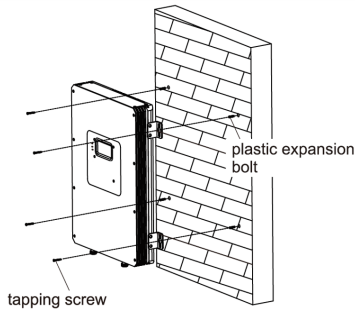

## 1.7 Run coaxial cable

Loosely run the supplied coaxial cable from your outdoor antenna to your booster connector marked "Outdoor". We recommend applying waterproof tape to fully waterproof the connection.

Connect the indoor antenna cables from your indoor antenna to the booster connector marked "Indoor". Tighten the connection by hand.

(After you have tested the system you can permanently secure the coaxial cable).

As you route and pull cabling, follow these general guidelines:

- Bend cables and route them smoothly, and protect the outer skin against any damage.
- Keep horizontal cables straight and fasten them with a tie every three to five feet.
- Bind and fasten vertical cables every six to eight feet.
- Waterproof all connectors between outdoor antenna and coaxial cables with waterproof tape to avoid water or other kinds of damage.
- Be careful when plugging the connector in so as not to damage the center pins on the connectors.

## 1.8 Power up your signal booster

Once all the following precautions have been taken, power on the signal booster.

1. Verify that you have left enough vertical separation space between the indoor and outdoor antennas.
2. Never point the front of outdoor antenna towards the indoor antenna.
3. Verify that the coaxial cables from both the outdoor antenna and the indoor antenna are properly connected to the signal booster before powering it up.
4. Carefully plug in the supplied power adaptor into the signal booster where it is marked 'DC 12V' and connect the other end to a power outlet.

The LED indicator marked power should light up green.

## 1.9 Booster Commissioning

**Overview:** The booster has a smart startup system. When you have finished the booster system installation and power on the booster, it will start its initialization process to check the received downlink signal from the cell site and the isolation status. This is an automatic process designed to ensure its best performance. This will take approximately 3-5 seconds.

After the booster starts up, please check if the coverage is good. If it is good, the booster system installation is complete. If the coverage is not adequate, please fully reread and understand the LCD, LED indications, control buttons and MGC function on your booster, as they will help you identify and solve any potential issues.

Check the downlink output power displayed by the LCD. It may vary dynamically at times between 1-3 dB which is normal due to outdoor signal conditions. It would be optimum that the output power reaches its maximum rated levels for the largest coverage; but you can always leave it set at lower levels if the coverage is adequate. Please bear in mind that it is nearly impossible to achieve 4 - 5 bars on every phone at all locations in a building.



Cellular phones will operate just fine if they are showing 1-2 bars. Some phones by different manufactures will often show widely different signal level results. Also, phones by the same manufacture can show different results if they have different software versions. Because of very large indoor RF signal multipath effects moving a phone only a few feet can result in large changes in its received signal level.

If the coverage is not adequate, please take the steps below as is appropriate for each situation:

1. The rated output power is reached, but the coverage is not enough or the signal in specific areas has not been improved.

- Check whether the indoor antenna is installed correctly. You may try to move the antenna location to improve coverage.
- If an indoor panel is used, check if adjusting the pointing direction of the indoor antenna makes any difference.
- Check whether it is necessary to add more indoor antennas since barriers such as walls will block the signal penetration.

2. The rated downlink output power is not reached.

1) Please adjust the outdoor antenna to get a stronger received signal from the tower to get higher downlink output power (not necessarily to reach rated value if the coverage is adequate). The max rated downlink power for this amplifier is 27 dBm.

2) Please observe the LCD display. If the displayed gain is much less than the rated value and "OSC Alarm" is flashing, it means the gain is being reduced by the ISO function because there is not enough isolation between an indoor antenna and the outdoor antenna.

## SIGNAL BOOSTER STATUS

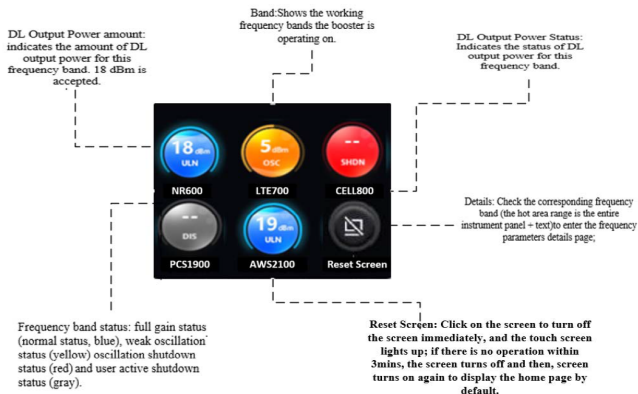

**Band:** Shows the working frequency bands where the booster is operating.

**UL/DL:** Shows real-time uplink and downlink gain(dB). These values will change slightly as the ALC or ISO makes changes to the gain to optimize coverage.

**Power:** Shows real-time downlink power(dBm) that the booster is delivering to the indoor antenna port. When the booster DL output power is lower than -10dBm, the value will display "---".

**OSC:** When the system does not have enough isolation between the outdoor and indoor antennas, the "OSC" indicator will be showing that the oscillation has lowered the gain in some bands to keep the system from oscillating. Enter the band detail and the LCD screen information will help with troubleshooting and display "OSC" value showing the current band or bands affected.

**SHUTDOWN:** In some rare situations the ALC or ISO will not be able to compensate for an oscillation condition or a downlink overload. When this happens the booster will shut off in the affected band and the LCD will indicate "SHDN". The band detail will help with troubleshooting and display which band or bands are affected.

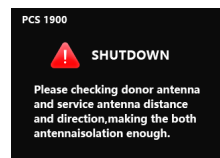
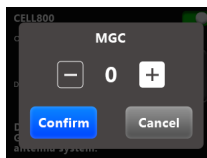
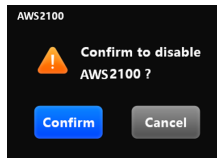
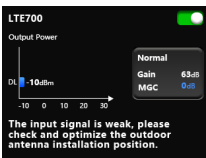



## Port description

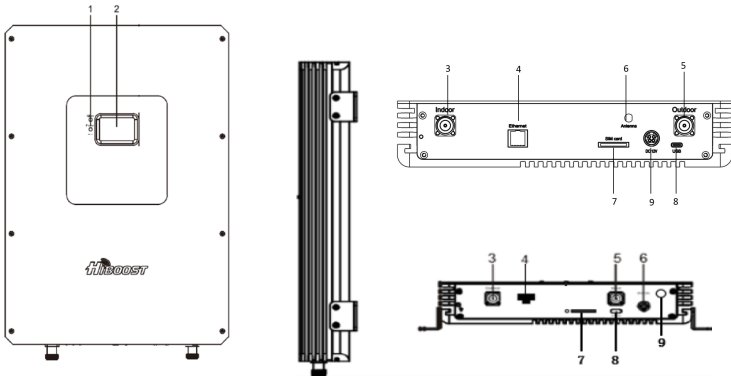

1-LED Light, 2-LCD, 3-Outdoor Antenna Port, 4-Ethernet Port, 5-Indoor Antenna Port, 6-Power Port, 7- SIM Card Slot, 8-Debug Port, 9- Antenna Port)

**"OSC" Status:** OSC status indicates if the booster has enough isolation between outdoor and indoor antennas to avoid loop back or so-called self-oscillation. Thanks to a very smart isolation gain processing, this amplifier is fully protected from creating interference with the carrier's local cell site networks. "OSC" showing on the LCD display means that the ISO function is doing its job and the self-oscillation has been eliminated.

LCD	Status	Definition	
OSC legend	Not showing	No loopback or no self-oscillation.	Working properly.
	Showing but current gain is not 42 dB less than rated gain.	Slight loop back or self-oscillation.	Working properly.
	Showing, and current gain is more than 42 dB below rated gain.	Deep loop back or self-oscillation.	Not working properly. Please check the Troubleshooting section to get solutions.

#### More about LCD status:

LCD	Status	Definition	
OSC	showing	ISO function working	Check coverage, leave it as is if it's good; if the coverage is poor, please check the Troubleshooting section to get solutions.
SHDN	showing	The booster automatically shuts off for protection from excessive downlink signal from tower or due to very severe self-oscillation.	Not working properly. Please check the Troubleshooting section to get solutions.
Disabled	showing		

**Note:** OSC status indicates that ISO and ALC functions are working properly, and the problems of self-oscillation and strong signal are corrected. In most cases, there is no need to take any additional measures, except for deep self-oscillation or too strong downlink signals that are overloading the amplifier. However, in most cases additional measures are not



mandatory, since the self-adaptive ALC system and isolation gain processing automatically solve most problems.

## LED Status

LED	Status	
Net LED	Off	Normal, no network connected
	Green	Connecting to network
	Green flashing	Active connection to management server

When the Alarm led indicators are flashing, please check the ISO and Alarm LED colors.

- Alarm LED flashing means that ISO function is working well and self-oscillation has been eliminated. Alarm LED will remain "Green" or will be "Slow Flashing Green".

**Note:** This improvement won't increase the coverage, but is mandatory to avoid causing interference to carrier's local cell site towers.

LED	Status	Definition	
Alarm LED	Green	No loopback or no self-oscillation.	Working properly.
	Slow Flashing Green	Slight loop back or self-oscillation.	Working properly.
	Quick Flashing Green	Deep loop back or self-oscillation.	Not working properly. Check coverage, leave it as is if it's good. Please check the Troubleshooting section to get solutions if coverage is not good.
	Red	The booster automatically shuts off for protection due to very severe self-oscillation.	Not working properly. Please check the Troubleshooting section to get solutions.

**Alarm LED:** Indicates the strength of received signal from the tower. Flashing Alarm means that the booster is receiving a strong signal in one or more of the bands. Alarm LED shall remain "Green" or "Slow Flashing Green". Slow flashing green indicates that everything is working well and the booster is working at nearly the optimum output power to achieve the best possible coverage



When any band shows OSC status with a yellow background, and the output power is less than the rated max output value, consider the donor antenna and service antenna isolation. The best performance is all bands show a blue circle, and the Alarm LED is solid, or slowly flashing.

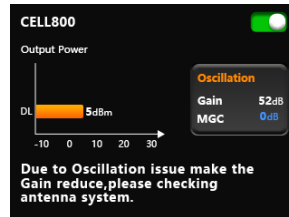

**Note:** The slow flashing Alarm status indicates that ISO and ALC functions are working properly and the problems of self-oscillation and strong downlink signals are fixed. In most cases, there is no need to take any additional measures except for deep self-oscillation or excessively strong signals from the tower. The self-adaptive ALC and isolation gain processing system automatically solve most problems.

## Control Buttons Operation and Manual gain control (MGC)

There are operation modes relative to the control keys:

- Touched any band circle, it can enter internal configuration menu.
- Touched the Screen outside circle, there are two options: reset or close screen.
- Touched screen any where, it will activate the screen.

Since the booster has a self-adaptive smart automatic level control (ALC) and isolation gain processing (ISO), most of the time manual adjustments are not required to achieve good coverage. However, in some cases where the ALC or ISO is working at a very high rate to adjust the gain and the Alarm LED is flashing more than once a second, a manual adjustment might be desired.



- Choose one band which need reduce the gain value.
- Click the MGC ,it will show currently working Gain and MGC value
- Enter the MGC,the gain will reduce by 1dB, Press " + " once shortly and the gain value will be reduced by 1dB.



**Note:** When adjusting the gain manually, please ensure that the uplink gain is equal to or not 5 dB less than the downlink gain setting. This avoids interference with the local cell site tower network.

When the LCD is in the fixed display mode, press the "Screen", then choosing "Reset" and "Confirm" this operate, the booster will reset the gain to the default manufacturer settings.

When the LCD is in the alarm display mode, enter per band and the LCD screen will turn on to help with troubleshooting and display the alarm indication showing the affected band or bands, and there are some suggestion message for your reference.

If none of the control keys are pushed within 5 minutes, the LCD screen will turn off. Pressing any where will return the display to the fixed mode.

## Network Status

Net	Green flashing	Connected to Server
	Off	No network connected
	Green	Connecting network
Alarm	Green	It is working properly
	Flashing green	Low level alarm
	Flashing Green or red	High level alarm

## TROUBLESHOOTING

Problem	Solution
The signal booster has no power.	Check that the AC outlet is working.
The booster's power is on but the phone is not connected to the network and still cannot communicate with the tower.	Check all the connections between the different components of the system. Change the direction of the outdoor donor antenna or its installed position. Use barriers (like buildings) to block signals of other operators.
Good downlink signal but with poor voice or link quality.	Check whether there's interference. Consult the operator whether the signal source base station is working OK.
The power is on but the coverage is not good.	First check LCD or LED status. Take the actions mentioned below.

### **Eliminate Flashing Alarm legend, and Quick Flashing Green, Quick Flashing Red LED problems:**

1. Adjust the outdoor antenna direction, keeping it away from indoor antenna. Restart booster.
2. Increase the vertical or horizontal distance between the outdoor antenna and indoor antenna. Restart booster.
3. Use barriers such as walls to increase the isolation.
4. Change the indoor antenna type to an antenna with a more directional antenna pattern. Orient the indoor antenna and outdoor antenna so they point in opposite directions.
5. Reduce the booster's downlink gain using the manual gain controls. Keep the uplink gain value and downlink gain value the same then restart the booster.

If the indoor antennas are connected through a splitter network locate the antenna that is causing the ISO alarm by disconnecting each indoor antenna one at a time and insert an inline attenuator to reduce the signal power going to that particular antenna.

**Note:** Uplink gain must be equal to or not less than 5dB below the downlink gain, to avoid interference with the local carrier's cell site network.

**Target:** The ISO issues are solved when the Alarm LED is "Green" or "Slow Flashing Green" or no flashing ISO legend.

### **Eliminate Flashing Alarm legend and Quick Flashing Green, Quick Flashing Red Alarm LED problems:**



1. Adjust the antennas' directions or locations to lower downlink received signal level.
2. Slowly reduce the downlink gain using the Manual Gain Controls.
3. If the above methods don't work, reduce the booster's gain with an external attenuator in line with the outdoor antenna or replace with lower gain antenna.

**Target:** The overload issues are fixed when the Alarm LED is "Green" or "Slow Flashing Green" or no red legend. Please note that a "Green" LED indication may result in smaller coverage area. This can be improved by adjusting the outdoor antenna to receive a stronger signal.

**Eliminate poor coverage problems when Power "----" legend or no flashing alarm status on LCD and Alarm LED is Green:**

1. If the signal in most areas has not been improved, please check below:
  - The weak downlink signal leads to the low output signal level. Change the direction or position of the outdoor antenna. You may also try replacing the outdoor antenna with a higher gain antenna to increase the incoming signal.
  - Check to see if it is necessary to add more indoor antennas. Barriers such as walls can block the signal indoors. You should also check the booster to make sure the power is maximized. Try installing more indoor antennas or replace the booster with a higher powered one.
2. If the signal in a small section of the building hasn't been improved, try the following:
  - Check to see if the indoor antenna is installed correctly. Try moving the antenna to improve coverage.
  - Try adjusting the direction the indoor antenna is pointing.
  - Check whether it is necessary to add one or more antennas to enhance the coverage of special areas.

**Remark:**

- When increasing the downlink gain make sure the isolation is adequate to prevent system oscillation.
- Recommended ways to increase output power: Adjust the outdoor antenna direction / location, or replace with higher gain antenna to increase received signal strength from the tower.

## **FCC RF EXPOSURE STATEMENT**

This equipment complies with FCC radiation exposure limits set forth for an uncontrolled environment. This equipment should be installed and operated with minimum distance 30cm between the radiator & your body.

This transmitter must not be co-located or operating in conjunction with any other antenna or transmitter.

## IC RF EXPOSURE STATEMENT

This device is in compliance with RF exposure limits. The minimum distance from your body to the antennas used with this device should be 20 CM.

Le présent appareil est conforme aux normes de conformité ou aux limites d'intensité de champ RF. La distance minimale du corps à utiliser le dispositif est de 20 CM.

Notice: the Manufacturer's rated output power of this equipment is for single carrier operation. For situations when multiple carrier signals are present, the rating would have to be reduced by 3.5dB, especially where the output signal is re-radiated and can cause interference to adjacent band users. This power reduction is to be by means of input power or gain reduction and not by an attenuator at the output of the device.

La puissance de sortie nominale indiquée par le fabricant pour cet appareil concerne son fonctionnement avec porteuse unique. Pour des appareils avec porteuses multiples, on doit réduire la valeur nominale de 3, 5 dB, surtout si le signal de sortie est retransmis et qu'il peut causer du brouillage aux utilisateurs de bandes adjacentes. Une telle réduction doit porter sur la puissance d'entrée ou sur le gain, et ne doit pas se faire au moyen d'un atténuateur raccordé à la sortie du dispositif.

## WARNING AND STATEMENT

Users of this product are cautioned to comply with following:



Booster should be installed with good grounding and lightning protection.



The power supply AC input voltage shall not exceed 240 VAC. Any maintenance operation shall be carried out only after cutting off power in advance. Only professional service is authorized for maintenance.



Do not dismantle the amplifier or maintain or replace any accessories without factory authorization. The equipment may be damaged and there is an electric shock hazard.



Do not open the booster, touch any module inside the booster, or open the cover of any module to touch the internal electronic components. The components can be damaged due to electrostatic discharge.



Please keep away from heating-equipment, because the booster will dissipate heat during operation. And do not cover booster with anything that influences heat-dissipation.



**WARNING.** This is NOT a CONSUMER device. It is designed for installation by FCC LICENSEES and QUALIFIED INSTALLERS. You MUST have an FCC LICENSE or express consent of an FCC Licensee to operate this device. Unauthorized use may result in significant forfeiture penalties, including penalties in excess of \$100,000 for each continuing violation.

Any Changes or modifications not expressly approved by the party responsible for compliance could void the user's authority to operate the equipment. This device complies with part 15 of the FCC Rules. Operation is subject to the following two conditions: (1) This device may not cause harmful interference, and (2) this device must accept any interference received, including interference that may cause undesired operation.

**WARNING:** E911 location information may not be provided or may be inaccurate for calls served BY USING THIS DEVICE.

**Notice:** When this device is operating in the 1710-1755 MHz band, the maximum antenna height should be a fixed height of 10 meters above ground. To meet the FCC EIRP limit, the antenna used with this amplifier must be connected by a cable with a minimum signal loss such that the combination of the antenna gain and cable loss shall not exceed 3 dB.

## SPECIFICATIONS

Uplink Frequency Range	663-698/ 698-716 /776- 787 / 824-849 / 1850-1915 / 1710-1755
Downlink Frequency Range	617-652/728-746 / 746- 757 / 869-894 / 1930-1995 / 2110-2155
Supported Standards	CDMA, WCDMA, HSPA+, EVDO, LTE ,NR and all cellular standards
Max. Gain	80 dB(UL)/ 85 dB(DL)
Max. Output Power	23 dBm(UL) / 27 dBm(DL)
MGC (Step Attenuation)	31 dB / 1 dB step
I/O Port	N-Female
Impedance	50 ohm
Environment Conditions	IP40
Dimensions	11*15.7*2.1 inch / 280*400*53 mm
Weight	≤17.6 lbs. / 8 kg
Power Supply	Input AC100~240 V,50/60 Hz, Output DC12 V /8.5A

## PRODUCT WARRANTY

**30-Day Money-Back:** All HiBoost products are protected by a 30-day money-back guarantee. If for any reason the performance of any product is not acceptable, the product may be returned to the reseller with a dated proof of purchase.

**3-Year Warranty** HiBoost Signal Boosters and kits are warranted for 3 years. Customers can choose to return the Signal Boosters and kits directly to the manufacturer at the purchaser's expense with a dated proof of purchase and a Returned Material Authorization (RMA) number supplied by HiBoost.

HiBoost will supply two options, repair or replace. HiBoost will cover the cost of delivery for the consumers located within the continental U.S.

This warranty does not apply to any Signal Boosters or kits determined by HiBoost to have been subjected to misuse, abuse, neglect, or mishandling that alters or damages physical or electronic properties. Failure to use a surge protected AC Power Strip with at least a 1000 Joule rating will void your warranty. Damage caused by lightning is not covered by this warranty.

All HiBoost products that are packaged with other HiBoost accessory products are intended for resale and used as a single integrated system. Such product kits are required to be sold to the end users or subsequent reseller as packaged. RMA numbers may be obtained by contacting Technical Support at 469-871-2552.





**HiBoost USA**

3150 Premier Dr., Ste. 130, Irving, TX 75063

Phone : (469) 871-2552

E-mail: [info@hiboost.com](mailto:info@hiboost.com)

Website: [www.hiboost.com](http://www.hiboost.com)