

CEL-FI QUATRA EVO

In-Building Cellular Coverage Solution

MODEL NUMBERS: Q42-Z1CNU, Q41-BXCU

Solving cellular coverage challenges for enterprise environments, CEL-FI QUATRA EVO is an active DAS hybrid that offers uniform, high-quality cellular signal throughout any building. As an all-digital solution, QUATRA EVO utilizes category cabling for RF and Power-over-Ethernet architecture to deliver industry-leading signal gain and scalability. In addition to unmatched performance, this cost-effective, carrier-grade system offers fiber expansion capabilities to scale up your coverage area and can be installed within days. QUATRA EVO is also carrier approved and unconditionally network safe.

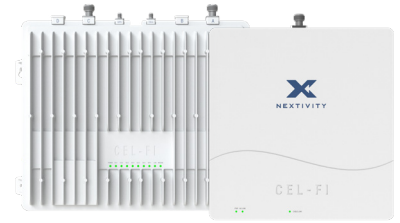

Network Unit (NU) Coverage Unit (CU)

Features and benefits include:

- Scalable all-digital active DAS hybrid for enterprise environments
- Flexible to configure for single or dual operator server applications
- In-Building cellular coverage solution for 4G and 5G with industry-leading signal gain up to 100 dB
- Carrier approved and unconditionally network safe
- Lossless RF signal and Power-over-Ethernet (PoE) distribution with easy-to-install category cable architecture
- Site installation flexibility with operator specific donor antenna or small cell signal source
- Remotely monitor and configure with Nextivity WAVE Portal cloud management

Bands

Bands	Network Unit Port	Downlink (MHz)	Uplink (MHz)	Technology/Bandwidth	Uplink Power (dBm)
2	A & C	1930-1990	1850-1910	5G/4G/20 MHz	22
4	A & C	2110-2155	1710-1755	5G/4G/20 MHz	22
5	A	869-894	824-849	5G/4G/HSPA/20 MHz	20
12	A	729-746	699-716	5G/4G/10 MHz	20
13	C	746-756	777-787	5G/4G/10 MHz	20
25	A & C	1930-1995	1850-1915	5G/4G/20 MHz	22

Specifications

Network Selection	Automatically best available (WAVE Portal for manual setting)
Duplex Modes	FDD
# of Relay Bands	4 max.
Independent Operators Supported	2 max.
Relay Bandwidth per NU Donor Port A or C	20 + 20 MHz max.
CU DL Power (All Bands)	16 dBm max.
System Gain	100 dB max.
Enterprise-Grade Echo Cancellation	30 dB min.
Noise Figure (All Bands)	7 dB max. at ambient (8 dB max. for Band 13 only)
Return Loss	-8 dB max.
UL Transmit EVM	8.5 %, 16-QAM with full RB allocation
DL Transmit EVM	8.5%, E-TM3.1
DL Input Level	-100 to -40 dBm
RF Interface Impedance (All Ports)	50 Ω
NU to CU Cable	2x Category Cables ANSI/TIA/EIA 568-B Compliant
NU to CU Cable Distance	328 ft (100 m) (656 ft (200 m) with CEL-FI QUATRA Range Extender) max.
Product Settings & SW Updates	WAVE Portal for Desktop

Network Unit Interface

Donor Port RF Connectors	2x N-type (f) (A - C -)
Power Port	IEC C14
Power Control	ON/OFF Switch
Cellular Modem Antenna Connector	1x SMA (f)
Cellular Modem GPS Antenna Port	1x SMA (f)
Cellular Modem SIM	Nano SIM (Included with 1-year free service)
Status LED (Power/LAN/Modem)	Bi-Color Green/Red
Status LED (6x CU Link/SFP+)	Green
CU Interface	2x RJ45 per CU
# of CU max. per NU	6
NU-Hub Expansion	SFP+
# of CU max per CEL-FI QUATRA EVO Fiber Hub (Q40-Z1FNU)	6
Monitoring & Management	LAN RJ45
COMPASS XR and Factory Debug	USB 2.0 Micro-B

Coverage Unit Interface

Server Antenna RF Connector	N-type (f)
NU Connectivity	2x RJ45
Status LED (Power)	Bi-Color Green/Red
Status LED(NU Link/Cable Link)	Green
Factory Debug Only	USB 2.0 Micro-B

Compliance

FCC	Part 15
	Part 20
	Part 22
	Part 24
	Part 27
UL	Yes
ISED	Yes

Power

Input Voltage	100-240 V
Input Current	3.5 A
Power Consumption	321.3 W max.
Power Cable	Type B (US) to IEC C13
Power Supply Cable	18 AWG
Power Supply Cable Length	6 ft (1.8m)
Coverage Unit Power	PoE+ per IEEE 802.3at

Environmental

Operating Temperature	32 to 104°F (0 to 40 °C)
Storage Temperature	-31 to 158°F (-35 to 70 °C)
Heat Dissipation	Passive Convection
Surface Temperature	111°F (44°C) max. at ambient
Non-condensing Humidity	0 to 95%
Ingress Protection Rating	IPX0

Mechanical & Packaging

Network Unit Box Contents	Network Unit
	1x AC Power Cable
	4x Mounting Screws
	4x Drywall Anchors
	1x Cellular Modem Antenna
Coverage Unit Box Contents	Coverage Unit
	4x Mounting Screws
	4x Drywall Anchors
Network Unit Dimensions	14.5 x 11.6 x 3.7 in (368.2 x 295.8 x 95.2 mm)
	Network Unit Weight
Network Unit Shipping Dimensions	20.35 x 14.69 x 5.39 in (517 x 373 x 137 mm)
Networking Unit Shipping Weight	15.2 lbs (6.89 kg)
Coverage Unit Dimensions	11.3 x 10.9 x 2.2 in (287.0 x 276.4 x 56.9 mm)
Coverage Unit Weight	10 lbs (4.54 kg)
Coverage Unit Shipping Dimensions	17.95 x 13.94 x 4.02 in (456 x 354 x 102 mm)
Coverage Unit Shipping Weight	12.1 lbs (5.49 kg)
Network Unit Mounting	Wall
Coverage Unit Mounting	Wall/Ceiling*

*CMA-100-100 available separately for ceiling mount

Note: Product specifications are subject to change without prior notification.

CEL-FI QUATRA EVO Network Unit (NU)

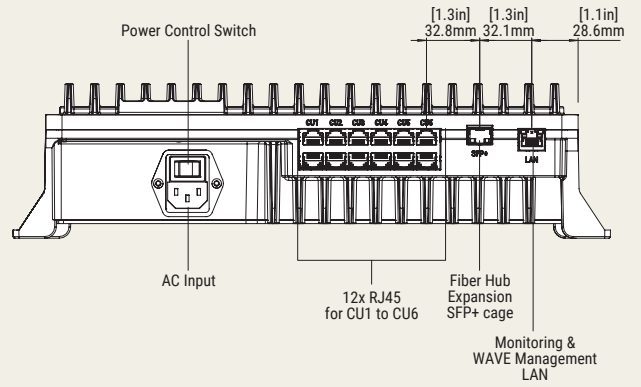
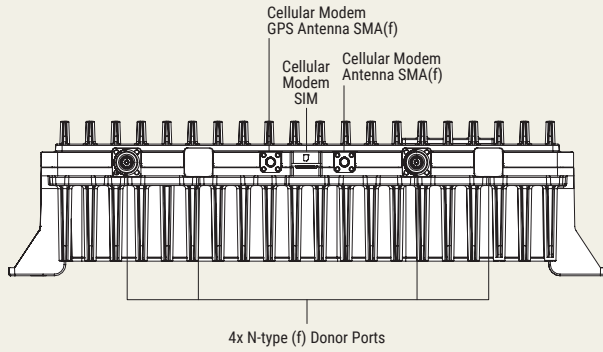
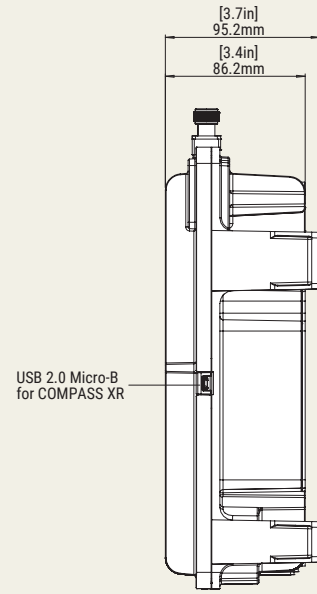
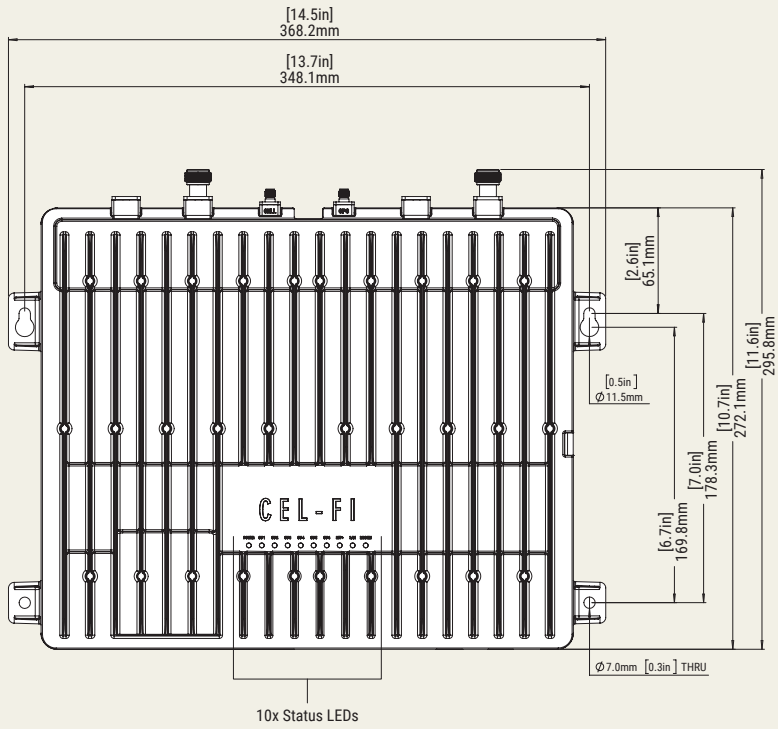

CEL-FI QUATRA EVO Coverage Unit (CU)

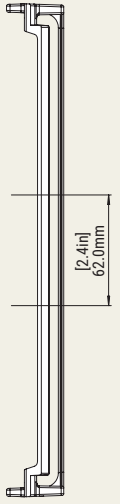
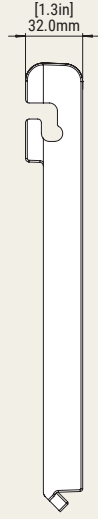
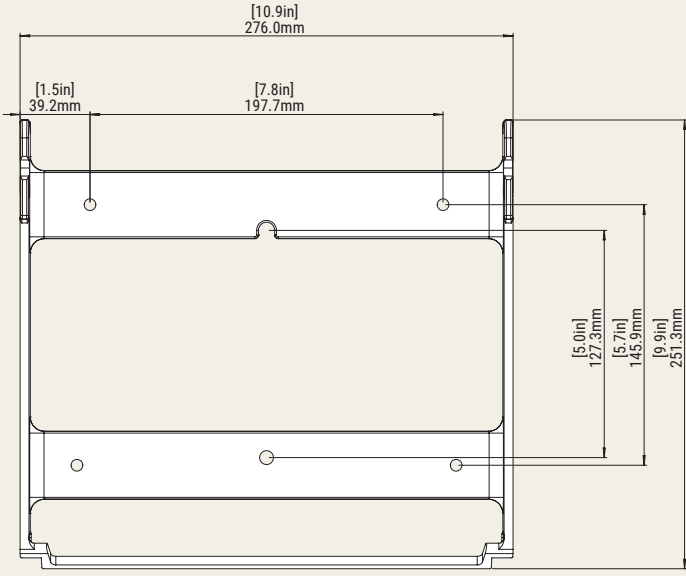
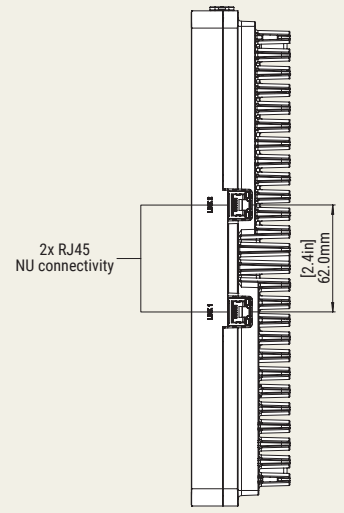
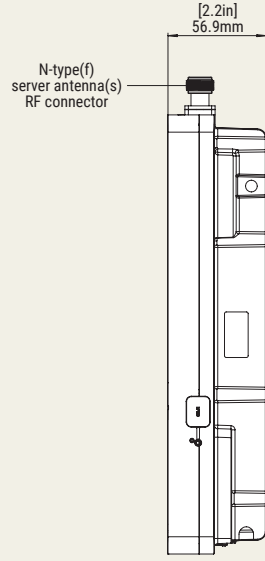
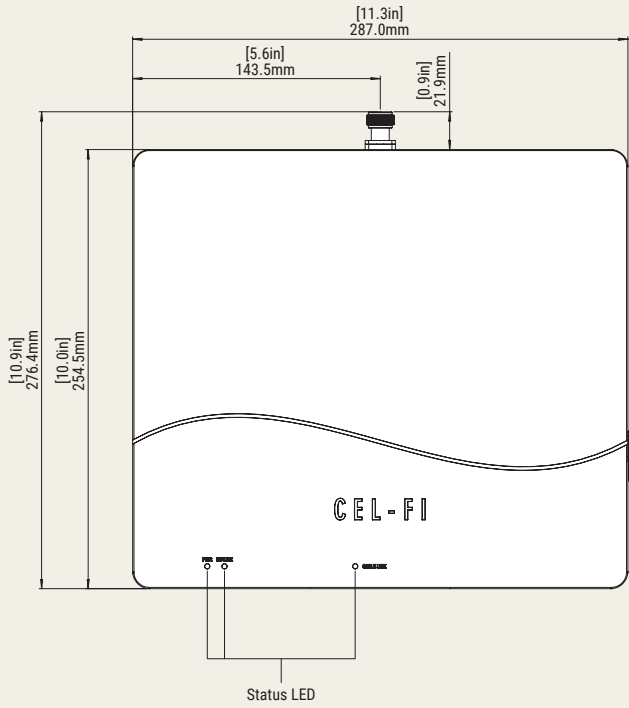

Example Diagram: 1 NU to 6 CUs

